

RP-300

Thermal Receipt printer

Technical manual



TABLE OF CONTENTS

1. General Specifications

- 1.1 Printing Specifications
- 1.2 Character Specifications
- 1.3 Auto Cutter
- 1.4 Paper Roll Supply Device
- 1.5 Paper Specifications
- 1.6 Printable Area
- 1.7 Printing and Cutting Positions
- 1.8 Internal Buffer
- 1.9 Electrical Characteristics
- 1.10 EMI and Safety Standards Applied
- 1.11 Reliability
- 1.12 Environmental Conditions

2. Configuration

- 2.1 Interface
 - 2.1.1 RS-232 serial interface
 - 2.1.2 Specifications
 - 2.1.3 Switching between on-line and off-line
 - 2.1.4 Interface connector terminal assignments and signal functions
 - 2.1.5 Serial interface connection example
 - 2.1.6 Centronics parallel interface
 - 2.1.7 Interface Connector
 - 2.1.8 Parallel Interface
 - 2.1.9 Data Receiving Timing(Compatibility Mode)

3. Connectors

- 3.1 Interface Connectors
- 3.2 Electrical Characteristics
- 3.3 Drawer kick-out Connector (Modular Connector)

4. Control Command Summary

1. General Specifications

1.1 Printing Specifications

- 1) Printing method: Thermal line printing
- 2) Dot density: 203dpi × 180dpi, 180dpi x 180dpi
- 3) Printing direction: Unidirectional with friction feed
- 4) Printing width: 72mm(2.83"), 576 dot/512 dot positions
- 5) Characters per line (default): Font A: 48, 42
Font B: 61, 56
- 6) Printed dot dimension: 0.11mm × 0.13mm
- 7) Printing speed: High speed mode:
30.7lines/second maximum
(1/6inch feed) (at 24V, 20 degree C)
Approximately 130mm/sec maximum
(approximately 5.11inchs/sec maximum)
 - **NOTE:** Speeds are switched depending on the applied voltage to the printer and head temperature conditions automatically.
 - **NOTE:** There may be variations in printing after switching the mode of the printing speed. To prevent this for logo printing with **ESC*** command, using a downloaded bit image is recommended. Change in printing speed does not occur during down loaded bit image printing.
- 8) Paper feed speed: Approximately 150mm/second
(approximately 5.9 inches/second)
(continuous paper feeding)
- 9) Line spacing (default): 1/6 inch (4.23mm)
Programmable by control command.

TECHNICAL MANUAL

1.2 Character Specifications

- 1) Number of characters: Alphanumeric characters: 95
 Extended graphics 128 × 7 pages
 (including one space page)
 International characters: 32
- i. English
 - ii. Hangul
 - iii. Chinese (GB2312,Big5)
 - iv. Kanji
- 2) Character structure: Font A: 12 × 24
 Font B: 9 × 24
 Hangul, Chinese: 24 × 24
 Font A is selected as the default

3) Character size:

	Standard		Double-height		Double-width		Double-width / Double-height	
	W × H(mm)	CPL	W × H(mm)	CPL	W × H(mm)	CPL	W × H(mm)	CPL
FontA 12× 24	1.25× 3.39	48/42	1.25× 6.77	48/42	2.5× 3.39	24/21	2.5× 6.77	24/21
FontB 9× 24	0.875× 3.39	64/56	0.875× 6.77	64/56	1.75× 3.39	32/28	1.75× 6.77	32/28
Hangul, GB 24× 24	3× 3.39	24/21	3× 6.77	24/21	6× 3.39	12/10	6× 6.77	12/10

Space between characters is not included.

CPL = Characters per line

1.3 Auto Cutter

Partial cut: Cutting with one point center uncut

NOTE: To prevent dot displacement, after cutting, paper must be fed approximately 1mm(14/360 inches) or more before printing.

1.4 Paper Roll Supply Device

1) Supply method: Drop-in paper roll

1.5 Paper Specification

- 1) Paper type: Specified thermal paper
- 2) Form: Paper roll
- 3) Paper width: 79.5 ± 0.5mm(3.13"± 0.02")
- 4) Paper roll size: Roll diameter: Maximum 83mm
Take-up paper roll width: 80 ± 0.5, 1.0mm(3.15"± 0.020", 0.04")
- 5) Paper roll spool diameter: Inside: 12mm(.47")

TITLE : RP-300

Document : 040823A

Revision : 01

Page4

08/ 23/ 2004

Outside: 18mm(.71")

NOTE: Paper must not be pasted to the paper roll spool.

1.6 Printable Area

1) Paper roll

The printable area of a paper with width of $79.5 \pm 0.5\text{mm}$ ($3.13'' \pm 0.02''$) is $72.2 \pm 0.2\text{mm}$ ($2.84'' \pm 0.008''$) (576dots) and the space on the right and left sides are approximately $3.7 \pm 0.2\text{mm}$ ($0.15'' \pm 0.079''$).

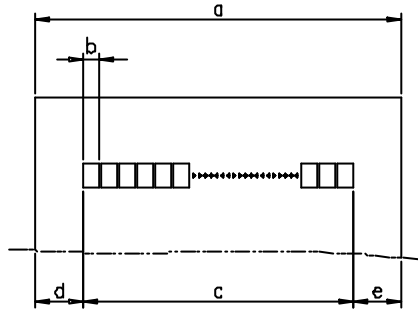

$b=0.125\text{mm} \pm 0.05\text{mm}$ ($.056'' \pm .002''$)
 $c=69\text{mm} \pm 0.2\text{mm}$ ($2.84'' \pm .008''$)
 $d=3.7 \pm 0.2\text{mm}$ ($0.15'' \pm 0.079''$)
 $e=3.7 \pm 0.2\text{mm}$ ($0.15'' \pm 0.079''$)
 [All the numeric values are typical.]

< Figure 1.1 Paper Roll Printable Area >

1.7 Printing and Cutting Positions

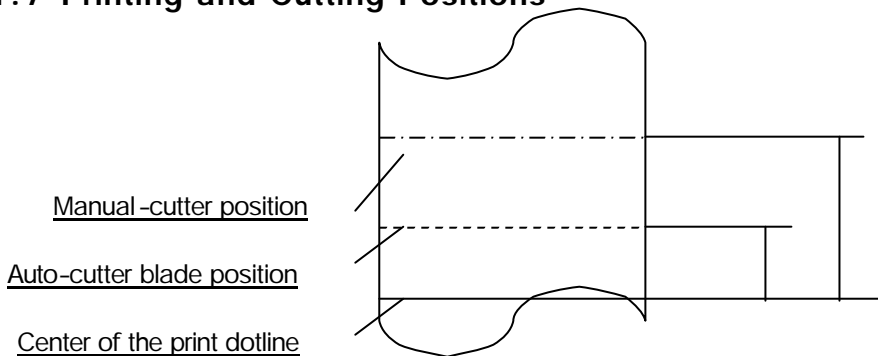

< Figure 1.2 Printing and Cutting Positions >

NOTE: Numeric values used here are typical values; the values may vary slightly as a result of paper slack or variations in the paper. Take the notice into account when setting the cutting position of the auto-cutter.

1.8 Internal Buffer

- 1) Receive buffer: 4kbyte
- 2) User-defined buffer: 1kbyte
- 3) NV bit image buffer: 64kbytes

1.9 Electrical Characteristics

- 1) Supply voltage: +24 VDC \pm 7%
- 4) Current consumption (at 24V):

Operating: Approx. 1.5A(at ASCII Printing)
Peak: Approx. 10A(at print duty 100%, For 10 seconds or less)
Stand-by: Approx. 0.15A

1.10 EMI and Safety Standards Applied

- 1) Europe: EMI – EN55022 CLASS A
EMS – EN61000-3-2, EN61000-3-3, EN50082-1
Safety Standard: EN60950

- 2) North America: EMI – FCC Part#15 Class A
Safety Standards – UL(1950), c-UL(No.950)

1.11 Reliability

- 1) MCBF: 60 million lines
(based on an average printing rate of 12.5% with paper thickness in the range 65 μm to 75 μm).
25 million lines
(based on an average printing rate of 12.5% with paper thickness in the range 76 μm to 150 μm)

- 2) Cutter Life: 1 million cuttings(if the paper thickness is between 65 and 100 μm)

1.12 Environmental Conditions

- 1) Temperature: Operating: 5° to 45°C (41° to 113°F)
Storage: -10° to 50°C (14° to 122°F)
(except for paper)

- 2) Humidity: Operating: 10 to 90%RH
Storage: 10 to 90%RH (except for paper)

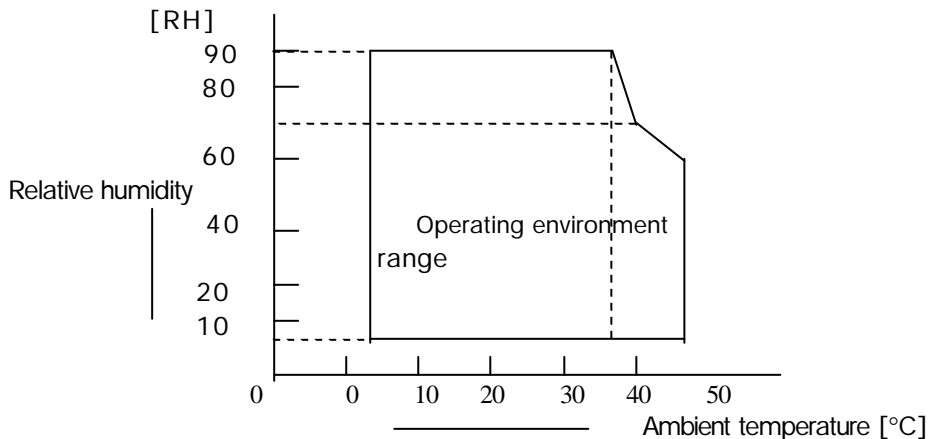

< Figure 1.3 Operating Temperature and Humidity Range >

2. Configuration

2.1 Interface

2.1.1 RS-232 serial interface

2.1.2 Specifications

Data transmission:	Serial
Synchronization:	Asynchronous
Handshaking:	DTR/DSR or XON/XOFF control
Signal levels:	MARK= -3 to -15V: Logic "1" SPACE= +3 to +15V: Logic "0"
Baud rage:	4800, 9600, 19200, 38400 bps
Data word length:	7 or 8 bits
Parity Settings:	None, even, odd
Stop bits:	1 or more
Connector (printer side):	Female DSUB -25 pin connector

NOTE: The data word length, baud rate, and parity depend on the DIP switch settings.

2.1.3 Switching between on-line and off-line

The printer does not have an on-line/off-line switch.

The printer goes off-line:

- Between when the power is turned on (including reset using the interface) and when the printer is ready to receive data.
- During the self-test.
- When the cover is open.
- During paper feeding using the paper feed button.
- When the printer stops printing due to a paper-end (in cases when an empty paper supply is detected by either paper roll end detector or the paper roll near-end detector with a printing halt feature by **ESC c4**).
- During macro executing stand by status.
- When a temporary abnormality occurs in the power supply voltage.
- When an error has occurred.

2.1.4 Interface connector terminal assignments and signal functions

PIN	SIGNAL	I/O	DESCRIPTION
2	TXD	-	Printer transmit data line RS-232C level
3	RXD	-	Printer receive data line RS-232C level
4, 20	DTR	Output	Printer handshake to host line RS-232C level
6	DSR	Input	Data Send Ready
1,7	GND	-	System Ground

2.1.5 Serial interface connection example

Host side	Printer side
TXD	RXD
DSR	DTR
RXD	TXD
DTR	DSR
FG	FG
SG	SG

NOTES: Set the handshaking so that the transmit data can be received.
 Transmit data to the printer after turning on the power and initializing the printer.

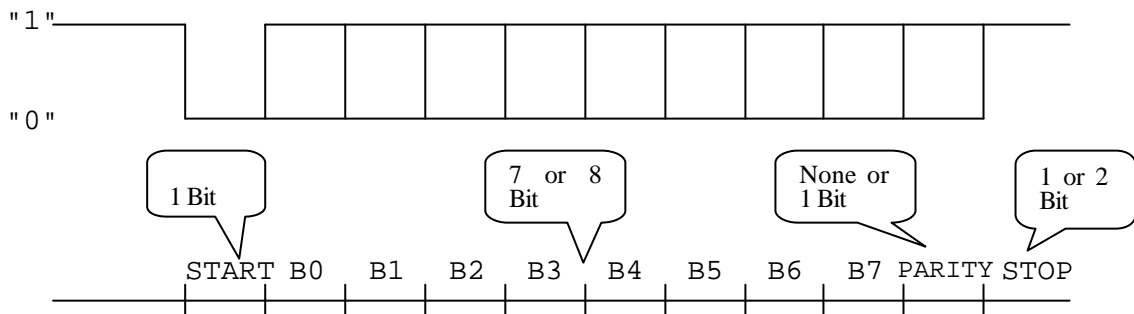

< Figure 2.1 Serial transmission bit frame >

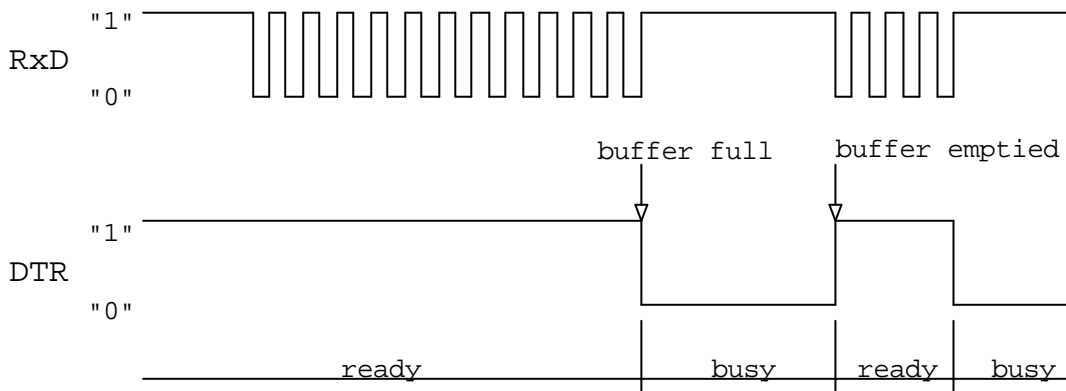

< Figure 2.2 Line transmission with protocol >

TECHNICAL MANUAL

2.1.6 Centronics parallel interface

PIN	SIGNAL	I/O	DESCRIPTION
1	STROBE -	Input	Synchronize signal Data received
2-9	DATA0-7	Input	Data bit Transmitted 0-7
10	ACK-	Output	Data receiving competed
11	BUSY	Output	Impossible to printer data receiving
12	PE	Output	Paper empty
13	SELECT	Output	Printer's status for ON/OFF line
14	AUTO FEED-	Input	ND
15	NC	-	
16	GROUND	-	System Ground
17	CHASSIS GND	-	System Ground
18	LOGIC-H	-	+5V
19-30	GROUND	-	System Ground
31	INIT-	Input	Initialize
32	ERROR-	Output	Printer Error
33	GROUND	-	System Ground
34	NC	-	
35	+5V	-	+5V
36	SELECT IN-	Input	ND

2.1.7 Interface Connector

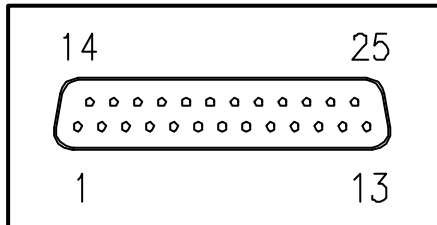

<D-SUB 25 Female Serial Port>

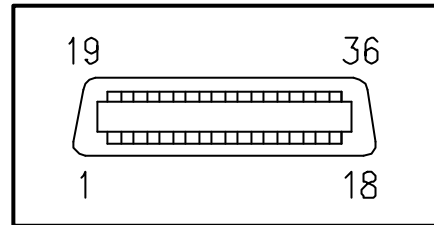

<D-SUB Centronics Parallel Port>

2.1.8 Parallel Interface

1) Specifications

- Data transmission: 8-bit parallel
- Synchronization: STROBE pulse supplied by host computer.
- Handshaking: ACK and BUSY
- Connector: D-SUB 25(male) or equivalent

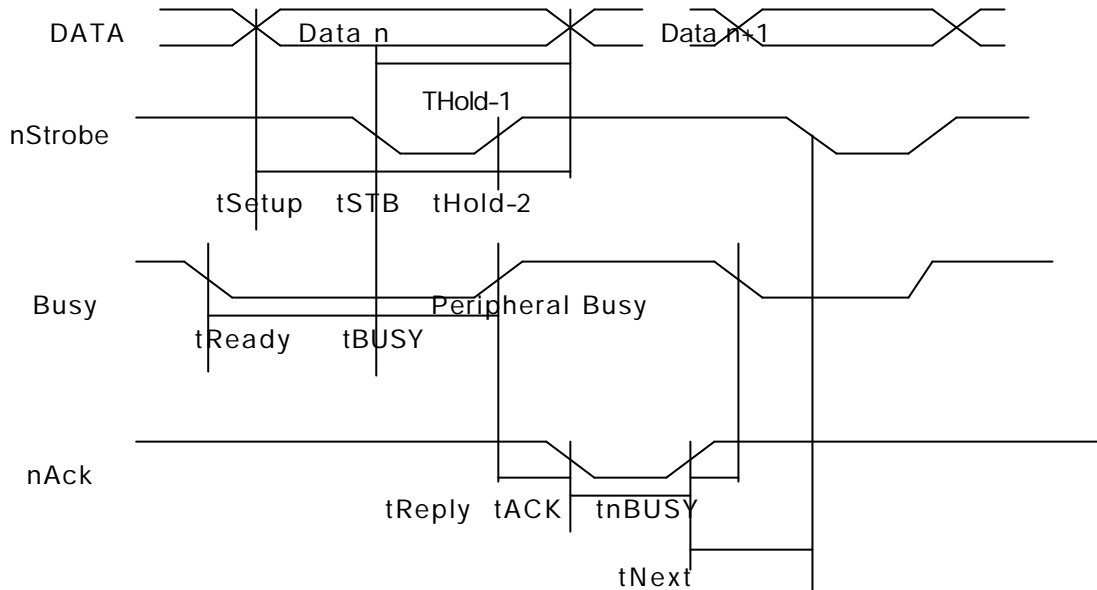

2.1.9 Data Receiving Timing (Compatibility Mode)

Characteristics	Symbol	Specifications	
		Min [ns]	Max [ns]
Data Hold Time (host)	tHold-1	--	500
Data Hold Time (printer)	tHold-2	--	--
Data Setup Time	tSetup	--	500
STROBE Pulse Width	tSTB	--	500
READY Cycle Idle Time	tReady	--	--
BUSY Output Delay Time	tBUSY	0	500
Data Processing Time	tReply	0	infinite
ACKNLG Pulse Width	tACK	500	10 _{us}
BUSY Release Time	tnBUSY	0	infinite
ACK Cycle Idle Time	tNEXT	--	0

*The printer latches data at a nStrobe and timing

3. Connectors

3.1 Interface Connectors

Refer to Section 2.1, Interface

3.2 Electrical Characteristics

- 1) Input Voltage: DC 24V ± 10%
- 2) Current Consumption: Operating: Approx. 1.5 A (at ASC II printing)
 Peak: Approx. 10 A (at print duty 100%, For 10 seconds or less)
 Stand-by: Approx. 0.15 A
- 3) Power Connector

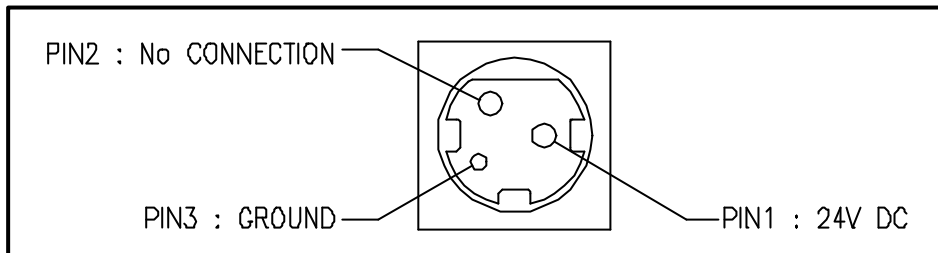

3.3 Drawer Kick-out Connector (Modular Connector)

The pulse specified by ESC p or DLE DC4 is output to this connector. The host can confirm the status of the input signal by using the **DLE EOT**, **GS a**, or **GS r** commands.

- 1) Pin assignments: Refer to Table 2.2.2
- 2) Connector model:
 Printer side: DAEEUN DEK-623PCB-6-B or Equivalent
 User side: 6-position 6-contact (RJ12 telephone jack)

< Drawer Kick-out Connector Pin Assignments >

Pin Number	Signal Name	Direction
1	Frame GND	-
2	Drawer kick-out drive signal 1	Output
3	Drawer open/close signal	Input
4	+24V	-
5	Drawer kick-out drive signal 2	Output
6	Signal GND	-

+24V is output through pin 4 when the power is turned on. However, pin 4 must be used only for the drawer.

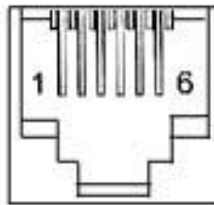

< **Figure 3.1 Drawer Kick-out Connector** >

3) Drawer kick-out drive signal

Output signal: Output voltage: Approximately 24V
 Output current: 1A or less

CAUTION: To avoid an over current, the resistance of the drawer kick-out solenoid must be 24 ohm or more.

Output waveform: Outputs the waveforms in Figure 3.2 to the points A and B in Figure 3.3
 t_1 (ON time) and t_2 (OFF time) are specified by **ESC p** or **DLE DC4**.

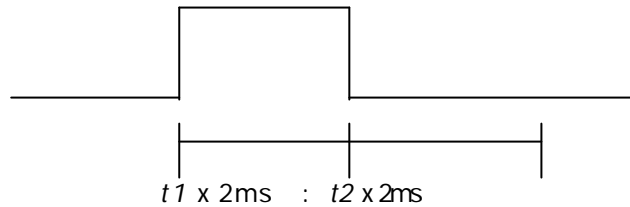

< **Figure 3.2 Drawer Kick-out Drive Signal Output Waveform** >

4) Drawer open/close signal

Input signal level (connector pin 3): "L"= 0 to 0.8V
 "H"= 3 to 5V

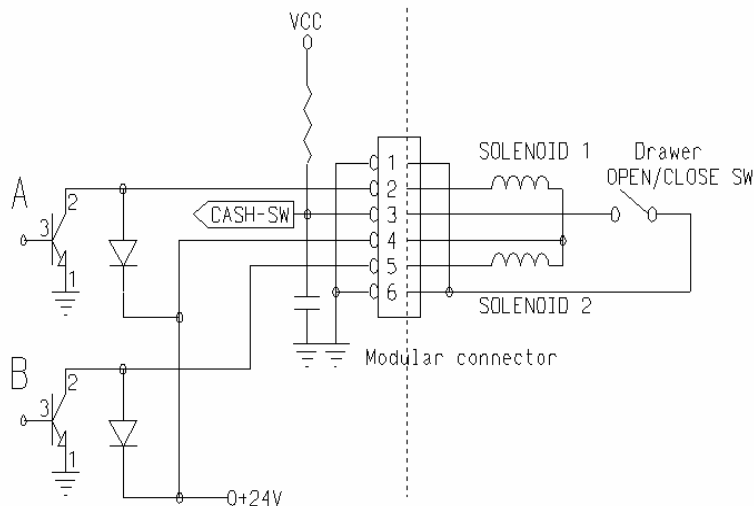

< **Figure 3.3 Drawer Circuitry** >

NOTE: 1. Use a shielded cable for the drawer connecto. cable.
 2. Two driver transistors cannot be energized simultaneously.

TECHNICAL MANUAL

3. The drawer drive duty must be as shown below.

$$\frac{\text{ON time}}{\text{(ON time + OFF time)}} \leq 0.2$$

4. Be sure to use the printer power supply (connector pin 4) for the drawer power source.
5. The resistance of the drawer kick-out solenoid must not be less than the specified. Otherwise, an over current could damage the solenoid.
6. Do not connect telecommunication network to the drawer kick-out connector.

5. Control Command summary

No.	Command	Function	
1	HT	Horizontal tab	
2	LF	Print and line feed	
3	CR	Print and carriage return	
4	FF	Print end position label to start printing	
5	CAN	Cancel print data in page mode	
6	DLE EOT	Real-time status transmission	
7	DLE ENQ	Real-time request to printer	
8	DLE DC4	Generate pulse at real-time	
9	ESC FF	Print data in page mode	
10	ESC SP	Set character right-side spacing	
11	ESC !	Set print mode	
12	ESC \$	Select/cancel user-defined character set	
13	ESC %	Define user-defined characters	
14	ESC &	Turn underline mode on/off	
15	ESC *	Set bit image mode	
16	ESC -	Turn underline mode on/off	
17	ESC 2	Set 1/6 inch line spacing	
18	ESC 3	Set line spacing using minimum units	
19	ESC =	Select peripheral device	
20	ESC ?	Cancel user-defined characters	
21	ESC @	Initialize printer	
22	ESC D	Set horizontal tab positions	
23	ESC E	Select emphasized mode	
24	ESC G	Select double-strike mode	
25	ESC J	Print end feed paper using minimum units	
26	ESC L	Select page mode	
27	ESC M	Select character font	
28	ESC R	Select international character set	
29	ESC S	Select standard mode	
30	ESC T	Select print direction in page mode	
31	ESC V	Set/cancel 90° cw rotated character	

Command Descriptions

Command Notation

- [Name]** *The name of the control command.*
- [Format]** *The code sequence.*
In this description, < > H denotes hexadecimal numbers, < > denotes decimal numbers and < > B denotes binary numbers.
[] k indicates the contents of the [] should be repeated k times.
- [Range]** *The allowable range for the arguments.*
- [Description]** *Description of the command function.*
- [Notes]** *If necessary provides important information on setting and using the printer command.*
- [Default]** *The default values for the commands.*
- [Reference]** *List related commands.*
- [Example]** *Example of using the commands.*

The numbers denoted by <>H is hexadecimal.

The numbers denoted by <>B is binary.

Print Commands

The RP series supports the following commands for printing characters and advancing paper.

HT

- [Name]** Horizontal tab
- [Format]** ASCII HT
Hex 09
Decimal 9
- [Description]** Moves the print position to the next tab position.
This command is ignored unless the next tab position has been set.
- [Notes]** Horizontal tab positions are set using "ESC D".
If this command is received when the printing position is at [printing area width +1], the printer executes print buffer-full printing of the current line and horizontal tab

TECHNICAL MANUAL

processing from the beginning of the next line.

[Reference] **ESC D**

LF

[Name] Print and line feed

[Format] ASCII LF
 Hex 0A
 Decimal 10

[Description] LF prints the data in the print buffer and feeds one line.
 The amount of paper fed per line is based on the value set using the line spacing
 command.
 The default setting is 1/6 inch.

[Reference] **ESC 2, ESC 3**

CR

[Name] Print and line feed

[Format] ASCII CR
 Hex 0D
 Decimal 13

[Description] When auto line feed is enabled, this command functions in the same way as **LF**.
 When auto line feed is disabled, this command is ignored.

[Reference] This command sets the print position to the beginning of the line.
 This command is available only with a parallel interface and is ignored with a serial
 interface.

FF

[Name] Print and return to standard mode (in page mode).

[Format] ASCII FF
 Hex 0C
 Decimal 12

[Description] FF prints the data in the print buffer and returns to standard mode.

TECHNICAL MANUAL

- [Notes] The printing area set by **ESC W** is reset to the default setting.
This command is effective only when page mode is selected.
All data are cleared after printing.
This command sets the print position to the beginning of the line.
- [Reference] **FF, ESC L, ESC S**

CAN

- [Name] Cancel print data in page mode
- [Format] ASCII CAN
Hex 18
Decimal 24
- [Description] In page mode, delete all the print data in the current printable area.
- [Notes] This command is enabled only in page mode.
If data that existed in the previously specified printable area also exists in the currently specified printable area, it is deleted.

DLE EOT n

- [Name] Real-time status transmission.
- [Format] ASCII DLE EOT n
Hex 10 04 n
Decimal 16 4 n
- [Range] 1<=n<=4
- [Description] Transmits the selected printer status specified by n in real-time, according to the following parameters:
n=1 : Transmit printer status
n=2 : Transmit off-line status
n=3 : Transmit error status
n=4 : Transmit paper roll sensor status
- [Notes] The status is transmitted whenever the data sequence of <10>H<04>H<n> (1 <= n <= 4) is received.
Example:
In **ESC * m nL nH d1...dk**, d1=<10>H, d2=<04>H, d3=<01>H
This command should not be used within the data sequence of another command that consists of 2 or more bytes.
Example:
If you attempt to transmit **ESC 3 n** to the printer, but DTR (DSR for the host

TECHNICAL MANUAL

computer) goes to MARK before n is transmitted and then **DLE EOT 3** interrupts before n is received, the code <10>H for **DLE EOT 3** is processed as the code for **ESC 3 <10>H**.

Even though the printer is not selected using **ESC =** (select peripheral device), this command is effective.

The printer transmits the current status. Each status is represented by one-byte data.

The printer transmits the status without confirming whether the host computer can receive data.

The printer executes this command upon receiving it.

This command is executed even when the printer is off-line, the receive buffer is full, or there is an error status with a serial interface model.

With a parallel interface model, this command can not be executed when the printer is busy. This command is executed even when the printer is off-line or there is an error status when DIP switch 2-1 is on with a parallel interface model.

When Auto Status Back (ASB) is enabled using the **GS a** command, the status transmitted by the **DLE EOT** command and the ASB status must be differentiated.

n = 1: Printer status

Bit	Off/On	Hex	Decimal	Function
0	Off	00	0	Not used. Fixed to Off
1	On	02	2	Not used. Fixed to On
2	Off	00	0	Drawer open/close signal is LOW (connector pin 3).
	On	04	4	Drawer open/close signal is HIGH (connector pin 3).
3	Off	00	0	On-line
	On	08	8	Off-line.
4	On	10	16	16 Not used. Fixed to On
5,6	-	-	-	Undefined.
7	Off	00	0	Not used. Fixed to Off.

n = 2: Off-line status

Bit	Off/On	Hex	Decimal	Function
0	Off	00	0	Not used. Fixed to Off
1	On	02	2	Not used. Fixed to On
2	Off	00	0	Cover is closed
	On	04	4	Cover is open
3	Off	00	0	Paper is not being fed by using the FEED button
	On	08	8	Paper is being fed by the FEED button
4	On	10	16	Not used. Fixed to On
5	Off	00	0	No paper-end stop
	On	20	32	Printing is being stopped
6	Off	00	0	No error
	On	40	64	Error occurs
7	Off	00	0	Not used. Fixed to Off

TECHNICAL MANUAL

Bit 5: Becomes on when the paper end sensor detects paper end and printing stops.

n= 3: Error status

Bit	Off/On	Hex	Decimal	Function
0	Off	00	0	Not used. Fixed to Off
1	On	02	2	Not used. Fixed to On
2	-	-	-	Undefined
3	Off	00	0	No auto-cutter error
	On	08	8	Auto-cutter error occurs
4	On	10	16	Not used. Fixed to On
5	Off	00	0	No unrecoverable error
	On	20	32	Unrecoverable error occurs
6	Off	00	0	No auto-recoverable error
	On	40	64	Auto recoverable error occurs
7	Off	00	0	Not used. Fixed to Off

Bit 3: If these errors occur due to paper jams or the like, it is possible to recover by correcting the cause of the error and executing **DLE ENQ n** (1 <= n <= 2). If an error due to a circuit failure (e.g. wire break) occurs, it is impossible to recover.

Bit 6: When printing is stopped due to high print head temperature until the print head temperature drops sufficiently or when the paper roll cover is open during printing, bit 6 is On.

n = 4: Continuous paper sensor status

Bit	Off/On	Hex	Decimal	Function
0	Off	00	0	Not used. Fixed to Off
1	On	02	2	Not used. Fixed to On
2,3	Off	00	0	Paper roll near-end sensor: paper adequate
	On	0C	12	Paper near-end is detected by the paper roll near-endsensor.
4	On	10	16	Not used. Fixed to On
5,6	Off	00	0	Paper roll sensor: Paper present
	On	60	96	Paper roll end detected by paper roll sensor
7	Off	00	0	Not used. Fixed to Off

[Reference] **DLE ENQ, GS a, GS r**

DLE ENQ n

[Name] Real-time request to printer

[Format] ASCII DLE EOT n
 Hex 10 05 n

TECHNICAL MANUAL

Decimal 16 5 n

[Range] 1<=n<=2

[Description] Responds to a request from the host computer. n specifies the requests as follows:

N	Request
1	Recover from an error and restart printing from the line where the error occurred
2	Recover from an error aft clearing the receive and print buffers

[Notes] This command is effective only when an auto-cutter error occurs
The printer starts processing data upon receiving this command.
This command is executed even when the printer is off-line, the receive buffer is full, or there is an error status with a serial interface model.
With a parallel interface model, this command can not be executed when the printer is busy. This command is executed even when the printer is off-line or there is an error status when DIP switch 2-1 is on with a parallel interface model.
The status is also transmitted whenever the data sequence of <10>H<05>H< n> (1<=n<=2) is received.

Example:

In **ESC * * * m nL nH dk**, d1 = <10>H, d2 = <05>H, d3 = <01>H

This command should not be contained within another command that consists of two or more bytes.

Example:

If you attempt to transmit **ESC 3 n** to the printer, but DTR (DSR for the host computer) goes to MARK before n is transmitted, and **DLE ENQ 2** interrupts before n is received, the code <10>H for **DLE ENQ 2** is processed as the code for **ESC 3 <10>H**.

DLE ENQ 2 enables the printer to recover from an error after clearing the data in the receive buffer and the print buffer. The printer retains the settings (by **ESC !**, **ESC 3**, etc.) that were in effect when the error occurred. The printer can be initialized completely by using this command and **ESC @**. This command is enabled only for errors that have the possibility of recovery, except for print head temperature error.

When the printer is disabled with **ESC =** (Select peripheral device), the error recovery functions (**DLE ENQ 1** and **DLE ENQ 2**) are enabled, and the other functions are disabled.

[Reference] **DLE EOT**

DLE DC4 n m t

[Name] Generate pulse at real-time

[Format] ASCII DLE EOT n m t
Hex 10 14 n m t
Decimal 16 20 n m t

TECHNICAL MANUAL

[Range] n=1
 m=0,1
 1<=t<=8

[Description] Outputs the pulse specified by t to connector pin m as follows:

m	Connector pin
1	Drawer kick-out connector pin 2
2	Drawer kick-out connector pin 5

The pulse ON time is [t x 100 ms] and the OFF time is [t x 100ms].

[Notes] When the printer is in an error status when this command is processed, this command is ignored.

When the pulse is output to the connector pin specified while **ESC p** or **DEL DC4** is executed while this command is processed, this command is ignored.

The printer executes this command upon receiving it.

With a serial interface model, this command is executed even when the printer is off-line, the receive buffer is full, or there is an error status.

With a parallel interface model, this command cannot be executed when the printer is busy. This command is executed even when the printer is off-line or there is an error status when DIP switch 2-1 is on.

If print data includes the same character strings as this command, the printer performs the same operation specified by this command. The user must consider this. This command should not be used within the data sequence of another command that consists of 2 or more bytes.

This command is effective even when the printer is disabled with **ESC =** (Select peripheral device).

[Reference] **ESC p**

ESC FF

[Name] Print data in page mode

[Format] ASCII ESC FF
 Hex 1B 0C
 Decimal 27 12

[Description] In page mode, prints all buffered data in the printable area collectively.

[Notes] This command is enabled only in page mode.
After printing, the printer does not clear the buffered data, setting value for **ESC T** and **ESC W**, and the position for buffering character data.

[Reference] **FF, ESC L, ESC S**

TECHNICAL MANUAL

ESC SP *n*

[Name]	Set right-side character spacing			
[Format]	ASCII	ESC	SP	<i>n</i>
	Hex	1B	20	<i>n</i>
	Decimal	27	32	<i>n</i>
[Range]	0 <= <i>n</i> <=255			
[Description]	ESC SP <i>n</i> sets the character spacing for the right side of the character to [<i>n</i> x (horizontal or vertical motion units)]. This command is not effective on Kanji characters.			
[Notes]	The right-side character spacing is [<i>n</i> x (horizontal or vertical motion unit)] inches. The right-side character spacing is [<i>n</i> x (horizontal or vertical motion unit)] inches. This command sets values independently in each mode (standard and page modes). The horizontal and vertical motion units are specified by "GS P". Changing the horizontal or vertical motion units does not affect the current right-side spacing. The "GS P" command can change the horizontal (and vertical) motion unit. However, the value cannot be less than the minimum horizontal movement amount, and it must be in even units of the minimum horizontal movement amount. In standard mode, the horizontal motion unit is used. The horizontal or vertical motion unit differs in page mode, depending on the starting position of the printable area as follows : When the starting position is set to the upper left or lower right of the printable area using "ESC T", the horizontal motion unit (x) is used. When the starting position is set to the upper right or lower left of the printable area using "ESC T", the vertical motion unit (y) is used. Any setting exceeding the maximum is converted to the maximum automatically.			
[Default]	<i>n</i> = 0			
[Reference]	GS P			

ESC ! *n*

[Name]	Select print mode(s)			
[Format]	ASCII	ESC	!	<i>n</i>
	Hex	1B	21	<i>n</i>
	Decimal	27	33	<i>n</i>
[Range]	0 <= <i>n</i> <=255			
[Description]	Selects print modes using <i>n</i> as follows:			

TECHNICAL MANUAL

Bit	Off/On	Hex	Decimal	Function
0	Off	00	0	Character font A (12x24) selected.
	On	01	1	Character font B (12x24) selected.
1	-	-	-	Undefined.
2	-	-	-	Undefined.
3	Off	00	0	Emphasized mode not selected.
	On	08	8	Emphasized mode selected.
4	Off	00	0	Double-height mode not selected.
	On	10	16	Double-height mode selected.
5	Off	00	0	Double-width mode not selected.
	On	20	32	Double-width mode selected.
6	-	-	-	Undefined.
7	Off	00	0	Underline mode not selected.
	On	80	128	Underline mode selected.

[Notes] When both double-height and double-width modes are selected, quadruple size characters are printed.
 The printer can underline all characters, but cannot underline the space set by "HT", "ESC \$", "ESC \", or 90° clockwise-rotated characters.
 The thickness of the underline is selected by "ESC -", regardless of the character size.
 When some characters in a line are double or more height, all the characters on the line are aligned at the baseline.
 "ESC E" Can also turn on or off emphasized mode. However, the setting of the last received command is effective.
 "ESC -" Can also turn on or off underline mode. However, the setting of the last received command effective.
 "GS !" Can also select character size, However, the setting of the last received command is effective.

[Default] $n = 0$

[Reference] **ESC E, ESC -, GS !**

ESC \$ *nL nH*

[Name] Set absolute print position

[Format]	ASCII	ESC	\$	<i>nL</i>	<i>nH</i>
	Hex	1B	24	<i>nL</i>	<i>nH</i>
	Decimal	27	36	<i>nL</i>	<i>nH</i>

[Range] $0 < nL < = 255$
 $0 < nH < = 255$

[Description] Sets the distance from the beginning of the line to the position at which subsequent characters are to be printed.

TECHNICAL MANUAL

- [Notes] The distance from the beginning of the line to the print position is $[(nL + nH \times 256) \times$ (vertical or horizontal motion unit)] inches.
Settings outside the specified printable area are ignored.
The horizontal and vertical motion units are specified by "GS P".
The "GS P" command can change the horizontal (and vertical) motion unit.
However, the value cannot be less than the minimum horizontal movement amount, and it must be in even units of the minimum horizontal movement amount. In standard mode, the horizontal motion unit is used.
The horizontal or vertical motion unit differs in page mode, depending on the starting position of the printable area as follows :
When the starting position is set to the upper left or lower right of the printable area using "ESC T", the horizontal motion unit (x) is used.
When the starting position is set to the upper right or lower left of the printable area using "ESC T", the vertical motion unit (y) is used.
- [Reference] **ESC \ , GS \$, GS \ , GS P**

ESC % n

- [Name] Select/cancel user-defined character set
- [Format]
- | | | | |
|---------|-----|----|---|
| ASCII | ESC | % | n |
| Hex | 1B | 25 | n |
| Decimal | 27 | 37 | n |
- [Range] $0 < n \leq 255$
- [Description] Selects or cancels the user-defined character set
When the LSB of n is 0, the user-defined character set is canceled.
When the LSB of n is 1, the user-defined character set is selected.
- [Notes] When the user-defined character set is canceled, the internal character set is automatically selected.
n is available only for the least significant bit.
- [Default] n = 0
- [Reference] **ESC & , ESC ?**

ESC & y c1 c2 [x1 d1... d(y x x1)].. [xk d1..d(y x xk)]

- [Name] Define user-defined characters
- [Format]
- | | | |
|---------|-----|--|
| ASCII | ESC | & y c1 c2 [x1 d1...d(y x x1)]...[xk d1...d(y x xk)] |
| Hex | 1B | 26 y c1 c2 [x1 d1...d(y x x1)]...[xk d1...d(y x xk)] |
| Decimal | 27 | 38 y c1 c2 [x1 d1...d(y x x1)]...[xk d1...d(y x xk)] |
- [Range] $y = 3$
 $32 \leq c1 \leq c2 \leq 126$

TECHNICAL MANUAL

$0 \leq x \leq 12$ Font A (12 x 24)
 $0 \leq x \leq 9$ Font B (9 x 24)
 $0 \leq d1 \dots d(y \times xk) \leq 255$
 [Description] Defines user-defined characters
 y specifies the number of bytes in the vertical direction.
 c1 specifies the beginning character code for the definition, and c2 specifies the final code.
 X specifies the number of dots in the horizontal direction.

[Notes] The allowable character code range is from ASCII code <20>H to <7E>(95characters).
 It is possible to define multiple characters for consecutive character codes.
 If only one character is desired, use $c1 = c2$.
 d is the dot data for the characters. The dot pattern is in the horizontal direction from the left side. Any remaining dots on the right side are blank.
 The data to define a user-defined character is $(y \times x)$ bytes.
 Set a corresponding bit to 1 to print a dot or 0 to not print a dot.
 This command can define different user-defined character patterns by each fonts.
 To select a font, use **ESC !**
 A user-defined character and a downloaded bit image cannot be defined simultaneously. When this command is executed, the downloaded bit image is cleared.

The user-defined character definition is cleared when:

- i. **ESC @** is executed.
- ii. **ESC ?** is executed.
- iii. **FS q** is executed.
- iv. **GS *** is executed.
- v. The printer is reset or the power is turned off.

When the user-defined characters are defined in font B (9 x 24), only the most significant bit of the 3rd byte of data in vertical direction is effective.

[Default] The internal character set

[Reference] **ESC %**, **ESC ?**

[Example]

- When font A (12 x 24) is selected.

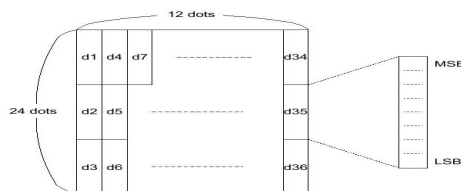

TECHNICAL MANUAL

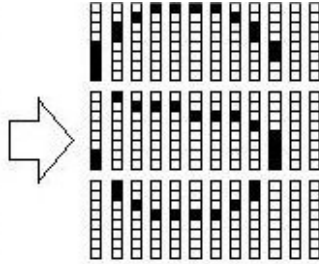
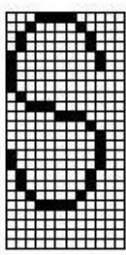

d1 = <0F>H d4 = <30>H d7 = <40>H
 d2 = <03>H d5 = <80>H d8 = <40>H
 d3 = <00>H d6 = <00>H d9 = <20>H

- When font B (9 × 24) is selected.

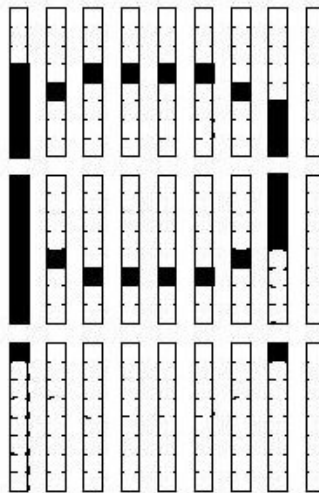
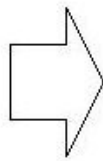
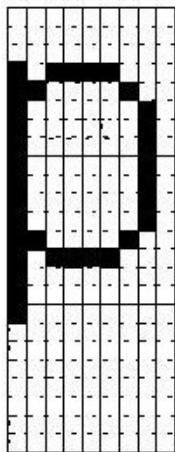
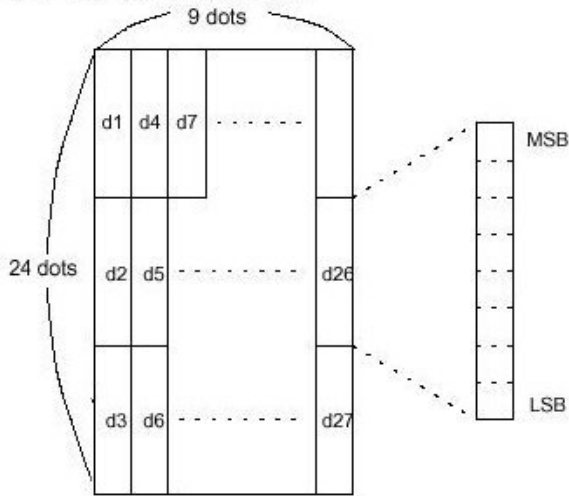

d1 = <1F>H d4 = <08>H d7 = <10>H...
 d2 = <FF>H d5 = <08>H d8 = <04>H...
 d3 = <80>H d6 = <00>H d9 = <00>H...

TECHNICAL MANUAL

ESC * *m nL nH [d1...dk]*

[Name] Select bit-image mode

[Format]

ASCII	ESC	*	<i>m</i>	<i>nL</i>	<i>nH[d1...dk]</i>
Hex	1B	2A	<i>m</i>	<i>nL</i>	<i>nH[d1...dk]</i>
Decimal	27	42	<i>m</i>	<i>nL</i>	<i>nH[d1...dk]</i>

[Range]

m = 0, 1, 32, 33
 $0 \leq nL \leq 255$
 $0 \leq nH \leq 3$
 $0 \leq d \leq 255$

[Description] Selects bit-image mode using *m* for the number of dots specified by (*nL*+ *nH*,x256). This command is used to print a predefined picture or logo. The modes selectable by *m* are follows;

<i>m</i>	Mode	Direction		Horizontal Direction	
		Vertical			
		NO. of Dots	Dot Density	Dot Density	Number of (Data(K))
0	8-dot single-density	8	60 DPI	101/90 DPI	$nL + nH \times 256$
1	8-dot double-density	8	60 DPI	203/180 DPI	$nL + nH \times 256$
32	24-dot single-density	24	180 DPI	101/90 DPI	$(nL + nH \times 256) \times 3$
33	24-dot double-density	24	180 DPI	203/180 DPI	$(nL + nH \times 256) \times 3$

[Notes]

The *nL* and *nH* indicate the number of dots of the bit image in the horizontal direction.
 The number of dots is calculated by $nL + nH \times 256$.
 If the bit-image data input exceeds the number of dots to be printed on a line, the excess data is ignored.
d indicates the bit-image data.
 Set a corresponding bit of 1 to print a dot or to 0 to not print a dot.
 If the value of *m* is out of the specified range, *nL* and data following are processed as normal data.
 If the width of the printing area set by "GS L" and "GS W" less than the width required by the data sent with the 'ESC * ' command the following will be performed on the line in question (but the printing cannot exceed the maximum printable area) :

- i. The width of the printing area is extended to the right to accommodate the amount of data.
- ii. If step i. does not provide sufficient width for the data, the left margin is reduced to accommodate the data.

For each bit of data in single-density mode, the printer prints two dots : for each bit of data in double-density mode, the printer prints one dot.
 This must be considered in calculating the amount of data that can be printed in one line.

TECHNICAL MANUAL

After printing a bit images the printer returns to normal data processing mode.
 This command is not affected by print modes (emphasized, double-strike, and underline etc.), except upside-down mode.

The relationship between the image data and the dots to be printed is as follows.

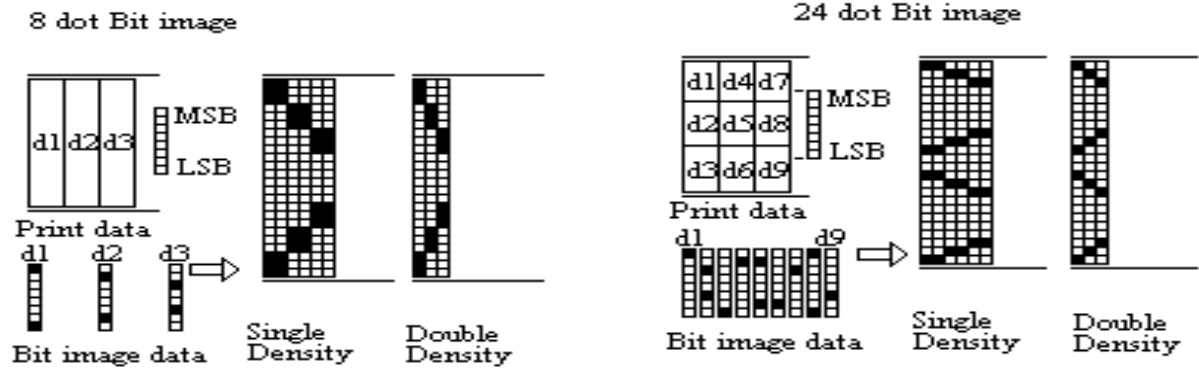

ESC - n

[Name] Turn underline mode on/off

[Format] ASCII ESC - n
 Hex 1B 2D n
 Decimal 27 45 n

[Range] $0 \leq n \leq 2$, $48 \leq n \leq 50$

[Description] Turns underline mode on or off, based on the following values of n .

n	Function
0, (48)	Turns off underline mode
1, (49)	Turns on underline mode (1-dot thick)
2, (50)	Turns on underline mode (2-dots thick)

[Notes] The printer underlines all characters (including right-side character spacing), but cannot underline the space set by "HT". The printer cannot underline 90° clockwise rotated characters and white/black inverted characters.

When underline mode is turned off by setting the value of n to 0 or 48, the following data is not underlined, and the underline thickness set before the mode is turned off does not change.

The default value thickness is 1 dot. Changing the character size does not affect the current underline thickness.

Underline mode can also be turned on or off by using "ESC !".

Note, however, that the last received is effective.

This command is not effective on Kanji characters.

[Default] $n = 0$

TECHNICAL MANUAL

[Reference] **ESC !**

ESC 2

[Name] Select 1/6-inch line spacing

[Format]	ASCII	ESC	2
	Hex	1B	32
	Decimal	27	50

[Description] ESC 2 sets the line spacing to 1/6 of an inch.

[Notes] The line spacing can be set independently in standard mode and in page mode.

[Reference] **ESC 3**

ESC 3 *n*

[Name] Set line spacing

[Format]	ASCII	ESC	3	<i>n</i>
	Hex	1B	33	<i>n</i>
	Decimal	27	51	<i>n</i>

[Range] $0 \leq n \leq 255$

[Description] ESC 3 *n* sets the line spacing to [*n* x (vertical or horizontal motion unit)] inches.
The default setting of the paper feed amount is 1/6 inch.
The default value in the vertical direction is 1/144 inch.

[Notes] The line spacing can be set independently in standard mode and in page mode.
The horizontal and vertical motion unit is specified by "**GS P**".
Changing the horizontal or vertical motion unit does not affect the current line spacing.
The "**GS P**" command can change the horizontal (and vertical) motion unit.
However, the value cannot be less than the minimum vertical movement amount, and it must be in even units of the minimum vertical movement amount.
In standard mode, the vertical motions until (y) is used.
This command function as follows in page mode, depending on the starting position of the printable area :

When the starting position is set to the upper left or lower right to the printable area using "**ESC T**", the vertical motion unit (y) is used.
When the starting position is set to the upper right or lower left of the printable area using **ESC T**, the horizontal motion unit (x) is used.

The maximum line spacing is 40 inches. When the setting value exceeds the

TECHNICAL MANUAL

maximum, it is converted to the maximum automatically.

[Default] Line space is equivalent to approximately 4.23mm(1/6inch)
[Reference] ESC 2, GS P

ESC = n

[Name] Set peripheral device

[Format] ASCII ESC = *n*
Hex 1B 3D *n*
Decimal 27 61 *n*

[Range] $1 < n \leq 3$

[Description] Selects device to which host computer sends data, using *n* as follows:
[Default] *n*=1

Bit	Off/On	Hex	Decimal	Function
0	Off	00	0	Printer disabled
	On	01	1	Printer enabled
1-7	-	-	-	Undefined

[Notes] When the printer is disabled, it ignores all data except for error-recovery commands (DLE EOT, DLE ENQ, DLE DC4) until it is enabled by this command.

ESC ? n

[Name] Cancel user-defined characters

[Format] ASCII ESC ? *n*
Hex 1B 3F *n*
Decimal 27 63 *n*

[Range] $32 \leq n \leq 126$

[Description] Cancels user-defined characters.

[Notes] This command cancels the pattern defined for the character code specified by *n*. After the user-defined characters is canceled, the corresponding pattern for the internal character is printed.
This command deletes the pattern defined for the specified code in the font selected by **ESC !**.
If a user-defined character has not been defined for the specified character code, the printer ignores this command.

TECHNICAL MANUAL

[Reference] **ESC &, ESC %**

ESC @

[Name] Initialize printer

[Format]	ASCII	ESC	@
	Hex	1B	40
	Decimal	27	64

[Description] ESC @ is initializes the printer.
All settings, including character font and line spacing settings, are canceled.

[Notes] The data in receive buffer is not cleared.
Adjustment amount of the label starting position using '**GS A**' command is not cleared.

ESC D [*n*1...*n**k*] NUL

[Name] Set horizontal tab positions

[Format]	ASCII	ESC	D		NUL
	Hex	1B	44	00	<i>n</i> 1... .. <i>n</i> <i>k</i>
	Decimal	27	68	0	<i>n</i> 1... .. <i>n</i> <i>k</i>

[Range] $1 \leq n \leq 255$
 $0 \leq k \leq 32$

[Description] Set is horizontal tab positions.
"*n*" specifies the column number for setting a horizontal tab position from the beginning of the line.
"*k*" indicates the total number of horizontal tab positions to be set.

[Notes] The horizontal tab position is stored as a value of [character width x *n*] measured from the beginning of the line.
The character width includes the right-side character spacing, and double-width characters are set with twice the width of normal characters.
This command cancels the previous horizontal tab settings.
When setting *n* = 8, the print position is moved to column 9 by sending "**HT**".
Up to 32 tab positions (*k*=32) can be set. Data exceeding 32-tab positions *s* is processed as normal data.
Transmit [*n*]*k* in ascending order and place a **NUL** code 0 at the end.
When [*n*]*k* is less than or equal to the preceding value [*n*]*k*-1, tab setting is finished and the following data is processed as normal data,
"**ESC D NUL**" cancels all horizontal tab positions.
When [*n*]*k* exceeds the number of characters printable on one line, the tab position

TECHNICAL MANUAL

set is equal to the maximum printable column plus 1.

The previously specified horizontal tab positions do not change. even if the character width changes.

[Default] The default tab positions are at intervals of 8 characters (columns 9, 17, 25, ...) for the font A (12 X 24).

[Reference] HT

ESC E *n*

[Name] Turn emphasized mode on/off

[Format]	ASCII	ESC	E	<i>n</i>
	Hex	1B	45	<i>n</i>
	Decimal	27	69	<i>n</i>

[Range] $0 \leq n \leq 255$ (Only the LSB of *n* is enabled.)

[Description] Turns emphasized mode on or off.
Only the lowest bit of *n* is valid.

When $n = \langle * * * * * 1 \rangle B$, the emphasized characters are selected.

When $n = \langle * * * * * 0 \rangle B$, the emphasized characters are canceled.

[Notes] "ESC !" Also turns on and off emphasized mode. However, the last received command is effective.

[Default] $n = 0$

[Reference] ESC !

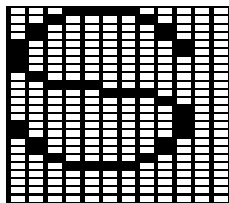

Normal
character

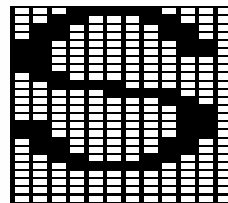

Emphasized
character

ESC G *n*

[Name] Select/cancel double-strike mode

[Format]	ASCII	ESC	G	<i>n</i>
	Hex	1B	47	<i>n</i>
	Decimal	27	71	<i>n</i>

TECHNICAL MANUAL

[Range]	$0 \leq n \leq 255$
[Description]	Select/cancel is double-strike mode. This command is available for all character types. Only the lowest bit of n is valid. When $n = \langle * * * * * 1 \rangle_B$, the double-strike mode is selected. When $n = \langle * * * * * 0 \rangle_B$, the double-strike mode is canceled.
[Notes]	In this printer, double-strike mode has the same function as emphasized mode.
[Default]	$n = 0$
[Reference]	ESC E

ESC J n

[Name]	Print and feed paper
[Format]	ASCII ESC J n Hex 1B 4A n Decimal 27 74 n
[Range]	$0 \leq n \leq 255$
[Description]	ESC J n Prints the data in the print buffer and feeds the paper [n x (vertical or horizontal motion unit) inches]. This command is used to temporarily feed a specific length without changing the line spacing set by other commands.
[Notes]	After printing is completed, this command sets the print starting position to the beginning of the line. The paper feed amount set by this command does not affect the values set by "ESC 2" or "ESC 3". The horizontal and vertical motion unit is specified by "GS P". The "GS P" command can change the vertical (and horizontal) motion unit. However, the value cannot be less than the minimum vertical movement, and it must be in even units of the minimum vertical movement amount. In standard mode, the printer uses the vertical motion unit. When this command is used in page mode, the command functions as follows, depending on the starting position of the printable area. When the starting position is set to the upper left or lower right of the printable area using "ESC T", the vertical motion unit (y) is used. When the starting position is set to the upper right or lower left of the printable area using "ESC T", the horizontal motion unit (x) is used. The maximum paper feed amount is 40 inches. Even if a paper feed amount of more

TECHNICAL MANUAL

than 40 inches is set, the printer feeds the paper only 40 inches.
When label mode is selected and a paper feed amount that exceeds the length of one label is set, the printer feeds the label paper to the next print starting position.

[Reference] **GS P**

ESC L

[Name] Select page mode

[Format]	ASCII	ESC	L
	Hex	1B	4C
	Decimal	27	76

[Description] Select from standard mode to page mode.

[Notes] This command is enabled only when input at the beginning of a line.
This command has no affect in page mode.
After printing by **FF** is completed or by using **ESC S**, the printer returns to standard mode.
This command sets the position where data is buffered to the position specified by **ESC T** within the printing area defined by **ESC W**.
This command is switches the setting for the following commands (in which the values can be set independently in standard mode and page mode) to those for page mode.

- i. Set right-side character spacing: **ESC SP**
- ii. Select 1/6-inch line spacing: **ESC 2**
- iii. Set line spacing: **ESC 3**

Setting for the following commands are effective only in page mode:

- i. Turn 90° clockwise rotation mode on/off: **ESC V**
- ii. Select justification: **ESC a**
- iii. Turn upside-down printing mode on/off: **ESC {**
- iv. Set left margin: **GS L**
- v. Set printable area width: **GS W**

The printer returns to standard mode by using the **ESC @**.

[Reference] **FF, CAN, ESC FF, ESC S, ESC T, ESC W, GS \$, GS **

ESC M n

[Name] Select character font

[Format]	ASCII	ESC	M	n
	Hex	1B	4D	n
	Decimal	27	77	n

[Range] n= 0, 1, 48, 49

TECHNICAL MANUAL

[Description] Selects character fonts

<i>n</i>	Function
0, (48)	Character font A(12 X 24) Selected
1, (49)	Character font B(9 X 24) Selected

ESC R *n*

[Name] Select international character set

[Format] ASCII ESC R *n*
Hex 1B 52 *n*
Decimal 27 82 *n*

[Range] 0<=*n* <=10

[Description] ESC R *n* selects an international character set from the following table.

<i>n</i>	Character Set
0	U. S. A
1	France
2	Germany
3	U. K.
4	Denmark I
5	Sweden
6	Italy
7	Spain
8	Japan
9	Norway
10	Denmark II
11	Spain II
12	Latin America
13	Korea

[Default] *n* = 0

[Reference] Character Code Tables

ESC S

[Name] Select standard mode

[Format] ASCII ESC S
Hex 1B 53

TECHNICAL MANUAL

Decimal 27 83

[Description] Select from page mode to standard mode.

[Notes] This command is effective only in page mode.
Data buffered in page mode and the printable area developed in page mode are cleared.

This command switches the setting for the following command (in which the values can be set independently in standard mode and page mode) to those for standard mode:

- i. Set right-side character spacing: **ESC SP**
- ii. Select 1/6-inch line spacing: **ESC 2**
- iii. Set line spacing: **ESC 3**

Setting for the following commands are effective only in standard mode:

- i. Select print direction in page mode: **ESC T**
- ii. Set printing area in page mode: **ESC W**

[Reference] **FF, ESC FF, ESC L**

ESC T *n*

[Name] Select print direction in page mode

[Format]

ASCII	ESC	T	<i>n</i>
Hex	1B	54	<i>n</i>
Decimal	27	84	<i>n</i>

[Range] $0 \leq n \leq 3$, $48 \leq n \leq 51$

[Description] Select the print direction and starting position in page mode.
n specifies the print direction and starting position as follows:

<i>N</i>	Print Direction	Starting Position
0, (48)	Left to right	Upper left(A in the figure)
1, (49)	Bottom to top	Lower left(B in the figure)
2, (50)	Right to left	Lower right(C in the figure)
3, (51)	Top to bottom	Upper right(D in the figure)

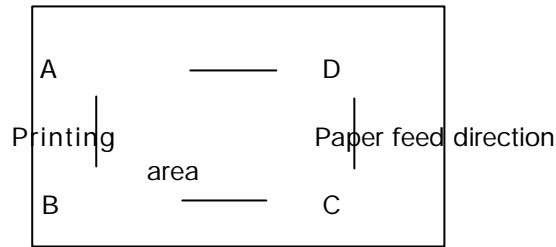

[Notes] When the command is input in standard mode, the printer executes only internal flag operation. This command does not affect printing in standard mode. This command sets the position where data is buffered within the printing area set by **ESC W**.

Parameters for horizontal or vertical motion units (x or y) differ as follows, depending on the starting position of the printing area:

If the starting position is the upper left or lower right of the printing area, data is buffered in the direction perpendicular to the paper feed direction.

Commands using horizontal motion units: **ESC SP**, **ESC \$**, **ESC **

Commands using vertical motion units: **ESC 3**, **ESC J**, **GS \$**, **GS **

If the starting position is the upper right or lower left of the printing area, data is buffered in the paper feed direction:

Commands using horizontal motion units: **ESC 3**, **ESC J**, **GS \$**, **GS **

Commands using vertical motion units: **ESC SP**, **ESC \$**, **ESC **

[Default] $n = 0$

[Reference] ESC \$, ESC L, ESC W, GS \$, GS P

ESC V n

[Name] Turn 90° clockwise rotation mode on/off

[Format]	ASCII	ESC	V	n
	Hex	1B	56	n
	Decimal	27	86	n

[Range] $0 \leq n \leq 1, 48 \leq n \leq 49$

[Description] Turns 90° clockwise rotation mode on or off.
 When $n = 1$ or 49 , 90° CW rotated characters are set.
 When $n = 0$ or 48 , 90° CW rotated characters are canceled.

[Notes] When underline mode is turned on, the printer does not underline 90° clockwise-rotated characters.

Double-width and double-height commands in 90° rotation mode enlarge characters in the opposite directions from double height and double-width commands in normal mode.

This command is input in page mode, the printer performs only internal flag

TECHNICAL MANUAL

operations.

[Default] $n = 0$

[Reference] **ESC !, ESC -**

ESC W *xL xH yL yH dxL dxH dyL dyH*

[Name] Set printing area in page mode

[Format]	ASCII	ESC	W	<i>xL xH yL yH dxL dxH dyL dyH</i>
	Hex	1B	57	<i>xL xH yL yH dxL dxH dyL dyH</i>
	Decimal	27	87	<i>xL xH yL yH dxL dxH dyL dyH</i>

[Range] $0 \leq xL \ xH \ yL \ yH \ dxL \ dxH \ dyL \ dyH \leq 255$

[Description] ESC W sets the position and size of the printing area. The horizontal starting position, vertical starting position, printing area width, and printing area height are defined as x_0 , y_0 , dx (inch), dy (inch), respectively. Each setting for the printable area is calculated as follow:
 $x_0 = [(xL + xH \times 256) \times (\text{horizontal motion unit})]$
 $y_0 = [(yL + yH \times 256) \times (\text{vertical motion unit})]$
 $dx = [(dxL + dxH \times 256) \times (\text{horizontal motion unit})]$
 $dy = [(dyL + dyH \times 256) \times (\text{vertical motion unit})]$

[Notes] If this command is input in standard mode, the printer executes printing in standard mode.
If the horizontal or vertical starting position is set outside the printable area, the printer stops command processing and processes the following data as normal data.
If the printing area width or height is set to 0, the printer stops command processing and processes the following data as normal data.
This command sets the position where data is buffered to the position specified by **ESC T** within the printing area.
If (horizontal starting position + printing area width) exceeds the printable area, the printing area width is automatically set to (horizontal printable - horizontal starting position).
If (vertical starting position + printing area height) exceeds the printable area, the printing area height is automatically set to (vertical printable area - vertical starting position).
The horizontal and vertical motion units are specified by **GS P**.
Changing the horizontal or vertical motion unit does not affect the current printing area.
The **GS P** command can change the horizontal (and vertical) motion unit. However, the value cannot be less than the minimum horizontal movement amount, and it must be in even units of minimum horizontal movement amount.
Use the horizontal motion unit for setting the horizontal starting position area width,

TECHNICAL MANUAL

and use the vertical motion unit for setting the vertical starting position and printing area height.

When the horizontal starting position, vertical starting position, printing area width, and printing area height are defined as $X, Y, Dx,$ and Dy respectively, the printing area is set as shown in the figure below.

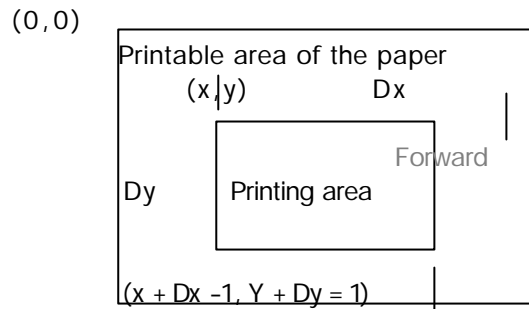

[Default] $xL = xH = yL = yH = 0$
 $dxL = 0, dxH = 2, dyL = 126, dyH = 6$

[Reference] **CAN, ESC L, ESC T, GS P**

ESC \ nL nH

[Name] Set relative print position

[Format]	ASCII	ESC	\	nL nH
	Hex	1B	5C	nL nH
	Decimal	27	92	nL nH

[Range] $0 \leq nL \leq 255$
 $0 \leq nH \leq 255$

[Description] Sets the print starting position based on the current position by using the horizontal or vertical motion unit.
 This command sets the distance from the current position to $[(nL + nH \times 256) \times$ (horizontal or vertical unit)].

[Notes] When pitch n is specified to the right : $nL + nH \times 256 = n$.
 When pitch n is specified to the left (the negative direction), use the complement of 65536.
 When pitch n is specified to the left : $nL + nH \times 256 = 65536 - n$.
 The print starting position moves from the current position to $[n \times$ (horizontal or vertical motion unit)].
 The horizontal and vertical motion units are specified by "GS P".
 The "GS P" command can change the horizontal (and vertical) motion unit.
 However, the value cannot be less than the minimum horizontal movement amount,

TECHNICAL MANUAL

and it must be in even units of the minimum horizontal movement amount.

In standard mode, the horizontal motion unit is used.

Any setting that exceeds the printable area is ignored.

In page mode, the horizontal or vertical motion unit differs as follows, depending on the starting point of the printing area :

When the starting position is set to the upper left or lower right of the printable area using "ESC T", the horizontal motion unit (x) is used.

When the starting position is set to the upper right or lower left of the printable area using "ESC T", the vertical motion unit (y) is used.

[Reference] **ESC \$, GS P**

ESC a n

[Name] Select justification

[Format] ASCII ESC a n
Hex 1B 61 n
Decimal 27 97 n

[Range] 0<=n <=2,48 <=n <=50

[Description] ESC a n aligns all the data in one line to the specified position.
ESC a n selects the type of justification as follows:

<i>n</i>	Justification
0, 48	Left justification
1, 49	Centering
2, 50	Right justification

[Notes] The command is enabled only when input at the beginning of the line.
If this command is input in page mode, the printer performs only internal flag operation.

This command does not affect printing in page mode.

Lines are justified within the specified printing area.

Spaces set by "HT", "ESC \$", and "ESC \ " are all justified.

[Default] n = 0

[Example]

Left justification	Centering	Right justification
ABC ABCD ABCDE	ABC ABCD ABCDE	ABC ABCD ABCDE

TECHNICAL MANUAL

ESC c 3 n

[Name] Select paper sensor(s) to output paper end signals

[Format] ASCII ESC c 3 n
 Hex 1B 63 33 n
 Decimal 27 99 51 n

[Range] $0 \leq n \leq 255$

[Description] Selects the paper sensor(s) to output paper end signals.

Bit	Off / On	Hex	Decimal	Function
0	Off	00	0	Paper roll near-end sensor disabled
	On	01	1	Paper roll near-end sensor enabled
1	Off	00	0	Paper roll near-end sensor disabled
	On	02	2	Paper roll near-end sensor enabled
2	Off	00	0	Paper roll end sensor disabled
	On	04	4	Paper roll end sensor enabled
3	Off	00	0	Paper roll end sensor disabled
	On	08	8	Paper roll end sensor enabled
4 - 7	-	-	-	Undefined

{Notes} It is possible to select multiple sensors to output signals. Then, if any of the sensors detects a paper end, the paper end signal is output.
The command is available only with a parallel interface and is ignored with a serial interface.
Sensor is switched when executing this command. The paper end signal switching be delayed depending on the receive buffer state.
If either bit 0 or bit 1 is on, the paper roll near-end sensor is selected as the paper sensor outputting paper-end signals
If either bit 2 or bit 3 is on, the paper roll end sensor is selected as the paper sensor outputting paper-end signals.
When all the sensors are disabled, the paper end signal always outputs a paper present status.

[Default] n = 15

ESC c 4 n

[Name] Select paper sensor(s) to stop printing

[Format] ASCII ESC c 4 n
 Hex 1B 63 34 n
 Decimal 27 99 52 n

[Range] $0 \leq n \leq 255$

TECHNICAL MANUAL

[Description] Selects the paper sensor(s) used to stop printing when a paper-end is detected, using *n* as follows.

Bit	Off / On	Hex	Decimal	Function
0	Off	00	0	Paper roll near end sensor disabled.
	On	01	1	Paper roll near end sensor enabled
1	Off	00	0	Paper roll near end sensor disabled
	On	02	2	Paper roll near end sensor enabled
2 – 7	-	-	-	Undefined

[Notes] When a paper sensor is enabled with this command, printing is stopped only when the corresponding paper is selected for printing.
When a paper-end is detected by the paper roll sensor, the printer goes off-line after printing stops.
When either bit 0 or 1 is on, the printer selects the paper roll near-end sensor for the paper sensor to stop printing.

[Default] *n* = 0

ESC c 5 n

[Name] Enable / disable panel buttons

[Format] ASCII ESC c 5 n
Hex 1B 63 35 n
Decimal 27 99 53 n

[Range] 0<=*n* <=255

[Description] Enables or disables the panel buttons.
When the LSB of *n* is 0, the panel buttons are enabled.
When the LSB of *n* is 1, the panel buttons are disabled.

[Notes] Only the lowest bit of *n* is valid.
When the panel buttons are disabled, none of them are usable when the printer cover is closed.
In this printer, the panel buttons are the FEED button.
In the macro ready mode, the FEED button are enabled regardless of the settings of this command; however, the paper cannot be fed by using these buttons.

ESC d n

[Name] Print and feed *n* lines

[Format] ASCII ESC d n

TITLE : RP-300

Document : 040823A

Revision : 01

TECHNICAL MANUAL

Hex 1B 64 *n*
 Decimal 27 100 *n*

[Range] $0 \leq n \leq 255$

[Description] ESC *d n* prints the data in the print buffer and feeds *n* lines.
 The amount of paper fed per line is based on the value set using the line spacing command.
 The default setting of the paper feed amount is 1/6 inch.

[Notes] This command sets the print starting position to the beginning of the line.
 This command does not affect the line spacing set by "ESC 2" or "ESC 3".
 The maximum paper feed amount is 40 inches. If the paper feed amount (*n* x line spacing) of more than 40 inches is specified, the printer feeds the paper only 40 inches.

[Reference] **ESC 2, ESC 3**

ESC p m t1 t2

[Name] Generate pulse

[Format] ASCII ESC p m t1 t2
 Hex 1B 70 m t1 t2
 Decimal 27 112 m t1 t2

[Range] $m = 0, 1, 48, 49$
 $0 \leq t1 \leq 255$ $0 \leq t2 \leq 255$

[Description] Outputs the pulse specified by t1 and t2 to connector pin m as follows.

<i>M</i>	Connector pin
0, (48)	Drawer kick-out connector pin2.
1, (49)	Drawer kick-out connector pin5.

[Notes] The pulse ON time is [t1 x 2 ms] and the OFF time is [t2 x 2 ms].
 If t2 < t1, the OFF time is [t1 x 2 ms]

[Reference] **DLE DC4**

ESC t n

[Name] Select character code table

[Format] ASCII ESC t *n*
 Hex 1B 74 *n*
 Decimal 27 116 *n*

TECHNICAL MANUAL

[Range] $0 \leq n \leq 5$, $n = 255$

[Description] Selects a page n from the character code table, as follows:

n	Page
0	0 (PC 437 [U.S.A., Standard Europe])
1	1 (Katakana)
2	2 (PC 850 [Multilingual])
3	3 (PC 860 [Portuguese])
4	4 (PC 863 [Canadian-French])
5	5 (PC 865 [Nordic])
255	Space page
17	PC 866 [Cyrillic 2]

[Notes] If n is outside the specified range, the printer ignores this command.

[Default] $n = 0$

ESC { n

[Name] Set/cancel upside-down character printing

[Format]	ASCII	ESC	{	n
	Hex	1B	7B	n
	Decimal	27	123	n

[Range] $0 \leq n \leq 255$

[Description] Sets or cancels upside-down character prints.
Only the lowest bit of n is valid.

When $n = \langle \text{*****} 1 \rangle \text{B}$, upside-down character printing is set.

When $n = \langle \text{*****} 0 \rangle \text{B}$, upside-down character printing is canceled.

[Notes] The upside-down character specification rotates normal characters on the line by 180° and prints them.

Valid only when input at the beginning of a line.

When this command is input in page mode, the printer performs only internal flag operations.

This command is disabled in page mode; setting in page mode is not affected.

[Default] $n = 0$

TECHNICAL MANUAL

[Example]

When upside-down character printing is canceled. When upside-down character printing is set.

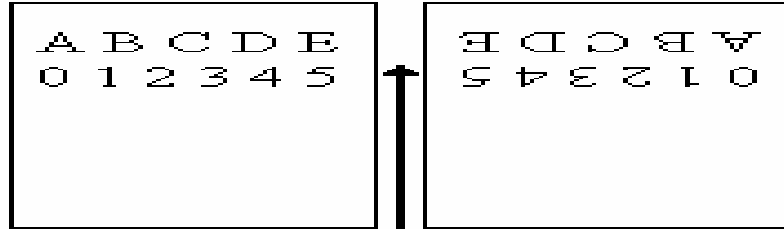

Paper feed direction

GS ! n

[Name] Select character size

[Format]	ASCII	GS	!	<i>n</i>	
	Hex	1D	21	<i>n</i>	
	Decimal		29	33	<i>n</i>

[Range] $0 \leq n \leq 255$

[Description]

Selects the character height using bits 0 to 3 and selects the character width using bits 4 to 7, as follows:

Bit	Off/On	Hex	decimal	Function
0				Character height selection. See Table 1 below.
1				
2				
3				
4				Character width selection. See Table 2 below.
5				
6				
7				

Table 1. Character Height Selection.

Hex	Decimal	Height (number of times)
00	0	1 (normal)
01	1	2 (double-Height)
02	2	3
03	3	4
04	4	5 Option
05	5	6 Option
06	6	7 Option
07	7	8 Option

Table 2. Character Width Selection

Hex	Decimal	Width (number of times)
00	0	1 (normal)
10	16	2 (double-Width)
20	32	3
30	48	4
40	64	5 Option
50	80	6 Option
60	96	7 Option
70	112	8 Option

TECHNICAL MANUAL

[Notes] This command is effective for all characters (except for HRI characters).
If n is outside of the defined range, this command is ignored.
In standard mode, the vertical direction is the paper feed direction, and the horizontal direction is perpendicular to the paper feed direction.
However, when character orientation changes in 90° clockwise-rotation mode, the relationship between vertical and horizontal directions is reversed.
In page mode, vertical and horizontal directions are based on the character orientation.
When characters are enlarged with different sizes on one line, all the characters on the line are aligned at the baseline.
The **ESC !** command can also turn double-width and double-height modes on or off.
However, the setting of the last received command is effective.

[Default] $n = 0$
[Reference] **ESC !**

GS \$ nL nH

[Name] Set absolute vertical print position in page mode

[Format] ASCII GS \$ nL nH
Hex 1D 24 nL nH
Decimal 29 36 nL nH

[Range] $0 \leq nL, nH \leq 255$

[Description] Sets the absolute vertical print starting position for buffer character data in page mode.
This command sets the absolute print position to $[(nL + nH \times 256) \times (\text{vertical or horizontal motion unit})]$ inches.
If the $[(nL + nH \times 256) \times (\text{vertical or horizontal motion unit})]$ exceeds the specified printing area, this command is ignored.
The horizontal starting buffer position does not move.
The reference starting position is that specified by **ESC T**.
This command operates as follows, depending on the starting position of the printing area specified by **ESC T**:
When the starting position is set to the upper left or lower right, this command sets the absolute position in the vertical direction.
When the starting position is set to the upper right or lower left, this command sets the absolute position in the horizontal direction.
The horizontal and vertical motion units are specified by **GS P**.
The **GS P** command can change the horizontal and vertical motion unit.
However, the value cannot be less than the minimum horizontal movement amount, and it must be in even units of the minimum horizontal movement amount.

[Reference] **ESC \$, ESC T, ESC W, ESC \, GS \, GS P**

TECHNICAL MANUAL

GS * x y [d1...d(x´y´8)]

[Name]	Define downloaded bit image					
[Format]	ASCII	GS	*	x	y	d1 ... d(x x y x 8)
	Hex	1D	2A	x	y	d1 ... d(x x y x 8)
	Decimal	29	42	x	y	d1 ... d(x x y x 8)
[Range]	$1 \leq x \leq 255$ $1 \leq y \leq 48$ $x \times y \leq 1536$ $0 \leq d \leq 255$					
[Description]	<p>Defines a downloaded bit image with the number of dots specified by x and y. x indicates the number of dots in the horizontal direction. y indicates the number of dots in the vertical direction. The number of dots is x x 8 in the horizontal direction and y x 8 in the vertical direction. d indicates bit-image data. Set bit to 1 to print a dot and to 0 to not print a dot.</p>					
[Notes]	<p>If x x y is outside of the specified range, ignores this command. A user-defined character and a downloaded bit image cannot be defined simultaneously. When this command is executed, the user-defined character is cleared. After a downloaded bit image is defined, it is available until ESC @ or ESC & is executed; the printer is reset or the power is turned off.</p>					
[Reference]	GS \					

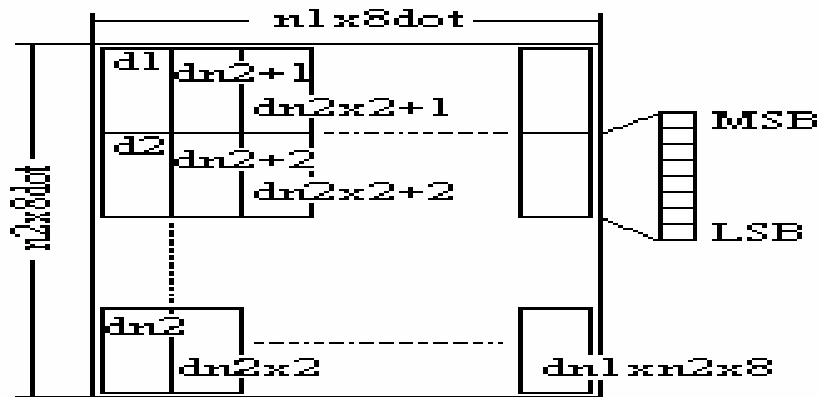

GS / m

[Name]	Print down-loaded bit image			
[Format]	ASCII	GS	/	m

TECHNICAL MANUAL

Hex	1D	2F	<i>m</i>
Decimal	29	47	<i>m</i>

[Range] $0 \leq m \leq 3, 48 \leq m \leq 51$

[Description] *GS / m* prints a down loaded bit image in mode *m*.
GS / m selects the print mode from the following table

<i>m</i>	Mode	Vertical Direction Dot Density	Horizontal Direction Dot Density
0,48	Normal	180 DPI	180 DPI
1,49	Double-width	180 DPI	90 DPI
2,50	Double-height	90 DPI	180 DPI
3,51	Quadruple	90DPI	90 DPI

[Notes] This command is ignored if a downloaded bit image has not been defined.
 In standard mode, this command is effective only when the on data exists in the print buffer.
 This command is not affected by print modes (emphasized, double-strike, underline, or character size, white/black reverse printing), except for upside down mode.
 If a down laded bit image exceeds the printing area, the excess data is not printed.
 If the printing area set by **GS L** and **GS W** is less than the width required by the data sent with the **GS ** command, the following will be performed on the line in question (but the printing cannot exceed the maximumprintable area):
 The width of the printing area is extended to the right to accommodate the amount of data.
 If the previous step does not provide sufficient width for the data, the left margin is reduced to accommodate the data.
 For each bit of data in normal mode (*m*=0, 48) and double width mode (*m*=2, 50), the printer prints one dot: for each bit of data in double width mode(*m*=1, 49) and quadruple mode (*m*=3, 51), the printer prints two dots.

[Reference] **GS ***

GS :

[Name] Start/end macro definition

[Format] ASCII **GS** :
 Hex 1D 3A
 Decimal 29 58

[Description] Starts or ends macro definition.

[Notes] Macro definition starts when this command is received during normal operation.
 Macro definition ends when this command is received during macro definition.

TECHNICAL MANUAL

When **GS ^** is received during macro definition, the printer ends macro definition and clears the definition.

Macro is not defined when the power is turned on.

The defined contents of the macro are not cleared by **ESC @**. Therefore, **ESC @** can be included in the contents of the macro definition.

If the printer receives **GS :** again immediately after previously receiving **GS :** the printer remains in the macro undefined state.

The contents of the macro can be defined up to 2048 bytes. If the macro definition exceed 2048 bytes, excess data is not stored.

[Reference] **GS ^**

GS B *n*

[Name] Turn white/black reverse printing mode

[Format]	ASCII	GS	B	<i>n</i>
	Hex	D	42	<i>n</i>
	Decimal	29	66	<i>n</i>

[Range] $0 \leq n \leq 255$

[Description] Turns on or off white/black reverse printing mode.
When the LSB of *n* is 0, white/black reverse printing mode is turned off.
When the LSB of *n* is 1, white/black reverse printing mode is turned on.

[Notes] Only the LSB of *n* is effective.
In reverse printing mode, Print dots and non-print dots are reversed. (Characters are printed in white on a black background.)
This command is available for built-in characters and user-defined characters.
White/black reverse printing mode has a higher priority than underline mode.
If underline mode is on, it is disabled (but not canceled) when white/black reverse mode is selected.
When reverse printing mode is on, it applies to character spacing set by **'ESC SP'**.
This command does not effect spacing skipped by bit images, downloaded bit images, bar codes (including Human Readable Interpretation (HRI) characters), **"HT"**, **"ESC \$"**, and **"ESC \"**.
This command does not effect the space between lines.
White/black reverse mode has a higher priority than underline mode.
Even if underline mode is on, it is disabled (but not canceled) when white/black reverse mode is selected.

[Default] $n = 0$

GS H *n*

TITLE : RP-300

Document : 040823A

Revision : 01

TECHNICAL MANUAL

[Name] Select printing position of HRI characters

[Format] ASCII GS H *n*
 Hex 1D 48 *n*
 Decimal 29 72 *n*

[Range] $0 \leq n \leq 3, 48 \leq n \leq 51$

[Description] GS H *n* selects the printing position of HRI characters when printing a bar code.
 GS H *n* selects the printing position from the following table.

<i>N</i>	Printing position
0, 48	Not printed
1, 49	Above the bar code
2, 50	Below the bar code
3, 51	Both above and below the bar code

HRI means **H**uman **R**eadable **I**nterpretation.

[Notes] HRI characters are printed using the font specified by **GS f**.

[Default] $n = 0$

[Reference] **GS f**, **GS K**

GS L *nL nH*

[Name] Set left margin

[Format] ASCII GS L *nL* *nH*
 Hex 1D 4C *nL* *nH*
 Decimal 29 76 *nL* *Nh*

[Range] $0 \leq nL \leq 255$
 $0 \leq nH \leq 255$

[Description] Sets the left margin using *nL* and *nH*.
 The left margin is set to $[(nL + nH \times 256) \times (\text{horizontal motion unit})]$ inches.

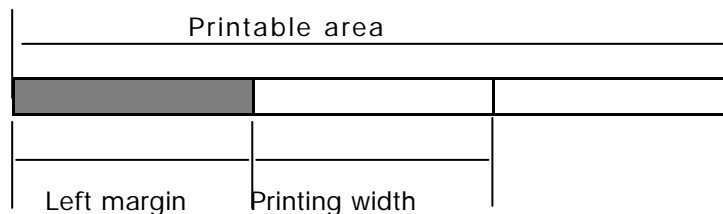

[Notes] This command is effective only of the beginning of a line.

TECHNICAL MANUAL

If this command is input in page made, the printer performs only internal flag operations.

This command does not affect printing in page made.

If the setting exceeds the printable area, the maximum value of the printable area is used.

The horizontal and vertical motion units are specified by **GS P**.

Changing the horizontal or vertical motion unit does not affect the current left margin.

The **GS P** command can change the horizontal (and vertical) motion units.

However, the value cannot be less than the minimum horizontal movement amount, and it must be in even units of the minimum horizontal movement amount.

[Default] $nL = 0, nH = 0$

[Reference] **GS W, GS P**

GS P x y

[Name] Set horizontal and vertical motion units

[Format]	ASCII	GS	P	x	y
	Hex	1D	50	x	y
	Decimal	29	80	x	y

[Range] $0 \leq x \leq 255$
 $0 \leq y \leq 255$

[Description] Sets the horizontal and vertical motion units to 1/x inch and 1/y inch, respectively. When x and u are set to 0, the default setting of each value is used. ($x = 180, y = 360$)

[Notes] The horizontal direction is perpendicular to the paper feed direction and the vertical direction is the paper feed direction.

In standard mode, the following commands use x or y, regardless character rotation (upside-down or 90° clockwise rotation):

Command using x: "ESC SP", "ESC \$", "ESC \", "GS L", "GS W"

Command using y: "ESC 3", "ESC J"

In page mad, the following command use x or y, depending on character orientation: When the print starting position is set to the upper left or lower right of the printing area using "ESC T" (data is buffered in the direction perpendicular to the paper feed direction):

Command using x: "ESC SP", "ESC \$", "ESC W", "ESC \"

Command using y: "ESC 3", "ESC J", "ESC W", "GS \$", "GS A", "GS /"

When the print starting position is set to the upper right or lower left of the printing area using "ESC T" (data is buffered in the paper feed direction):

Command using x: "ESC 3", "ESC J", "ESC W", "GS \$", "GS /"

TECHNICAL MANUAL

Command using y: "ESC SP", "ESC \$", "ESC W", "ESC \",
"GS A"

This command does not affect the previously specified values.

The calculated result from combining this command with others is truncated to the minimum value of the mechanical pitch or an exact multiple of the value.

[Default] $x = 180, y = 360$

[Reference] **ESC SP, ESC \$, ESC 3, ESC J, ESC W, ESC \, GS &, GS A, GS L, GS W, GS /**

(1) GS V m , (2) GS V m n

[Name] Select cut mode and cut paper

[Format]	(1) ASCII	GS	V	m	
	Hex	1D	56	m	
	Decimal	29	86	<i>m</i>	
	(2) ASCII	GS	V	m	n
	Hex	1D	56	m	n
	Decimal	29	86	<i>m</i>	<i>n</i>

[Range] (1) $m = 1, 49$
(2) $m = 66, 0 \leq n \leq 255$

[Description] Selects a mode for cutting paper and executes paper cutting. The value of m selects the mode as follows:

<i>M</i>	Print mode
0, 1, 49	Partial cut(one point center uncut)
66	Feeds paper(cutting position + [n x(vertical motion unit)]) , and cuts the paper partially(one point center uncut)

[Notes for (1) and (2)] This command is effective only processed at the beginning of a line.

[Note for (1)] Only the partial cut is available; there is no full cut.

[Notes for (2)] When $n = 0$, the printer feeds the paper to the cutting position and cuts it.
When $n \neq 0$, the printer feeds the paper to (cutting position + [n × vertical motion unit]) and cuts it.

The horizontal and vertical motion unit are specified by **GS P**.

The paper feed amount is calculated using the vertical motion unit (y).

However, the value cannot be less than the minimum horizontal movement amount, and it must be in even units of the minimum horizontal movement amount.

GS W

[Name] Set printing area width

TECHNICAL MANUAL

[Format] ASCII GS W nL nH
 Hex 1D 57 nL nH
 Decimal 29 87 nL nH

[Range] $0 \leq nL \leq 255$
 $0 \leq nH \leq 255$

[Description] Sets the printing area width to the area specified by nL and nH
 The printing area width is set to $[(nL + nH \times 256) \times \text{horizontal motion unit}]$ inches.

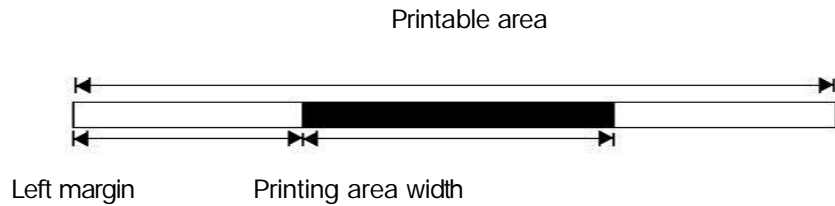

[Notes] This command is effective only processed at the beginning of the line.
 In page mode, the printer performs only internal flag operations.
 This command does not affect printing in page mode.
 If the [left margin + printing area width] exceeds the printable area, [printable area width - left margin] is used.
 The horizontal and vertical motion units are specified by **GS P**. Changing the horizontal and vertical motion units does not affect the current left margin.
 The horizontal motion unit (x) is used for calculating the printing area width.
 The calculated result is truncated to the minimum value of the mechanical pitch.
 If the width set for the printing area is less than the width of one character, when the character data is developed, the following processing is performed:
 i. The printing area width is extended to the right to accommodate one character.

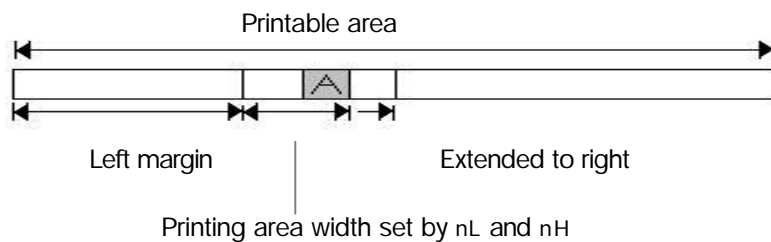

ii. If the printing area width cannot be extended sufficiently, the left margin is reduced to accommodate one character

TECHNICAL MANUAL

Printable area

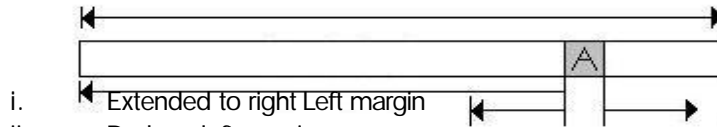

- i. Extended to right Left margin
- ii. Reduce left margin
- iii. If the printing area width cannot be extended sufficiently, the right space is reduced.

If the width set for the printing area is less than one line in vertical, the following processing is performed only on the line in question when data other than character data (e.g., bit image, user-defined bit image) is developed:

- i. The printing area width is extended to the right to accommodate one line in vertical for the bit image within the printable area.
- ii. If the printing area width cannot be extended sufficiently, the left margin is reduced to accommodate one line in vertical.

The commands which set the printing area width for bit image printing and its minimum widths are as follows:

Bit image (**ESC** * * * *):

Single density mode = 2 dots

Double density mode = 1 dot

Downloaded bit image (**GS** /):

Double width mode or Quadruple mode = 2 dots

Normal mode or Double-height mode = 1 dot

Normal mode or Double-height mode = 1 dot

[Default] nL = 0, nH = 2
 For 58mm paper width model; nL = 104, nH = 1

[Reference] **GS L**, **GS P**

GS \ nL nH

[Name] Set relative vertical print position in page mode

[Format]	ASCII	GS	\	nL	nH	
	Hex		1D	5C	nL	nH
	Decimal	29	92	nL	nH	

[Range] $0 \leq nL \leq 255$
 $0 \leq nH \leq 255$

[Description] Sets the relative vertical print starting position from the current position in page mode.
 This command sets the distance from the current position to [(nL + nH x 256) vertical or horizontal motion unit] inches.

[Notes] This command is ignored unless page mode is selected.

TECHNICAL MANUAL

When pitch N is specified to the movement downward:

$$nL + nH \times 256 = N$$

When pitch N is specified to the movement upward (the negative direction), use the complement of 65536.

When pitch N is specified to the movement upward:

$$nL + nH \times 256 = 65536 - N$$

Any setting that exceeds the specified printing area is ignored.

This command function as follows, depending on the print starting position set by **ESC T**:

- i. When the starting position is set to the upper left or lower right of the printing, the vertical motion unit (y) is used.
- ii. When the starting position is set to the upper right or lower left of the printing area, the horizontal motion unit (x) is used.

The horizontal and vertical motion unit are specified by **GS P**.

The **GS P** command can change the horizontal (and vertical) motion unit.

However, the value cannot be less than the minimum horizontal movement amount, and it must be in even units of the minimum horizontal movement amount.

[Reference] **ESC \$, ESC T, ESC W, ESC \, GS \$, GS P**

GS ^ r t m

[Name] Execute macro

[Format]	ASCII	GS	^	r	t	m
	Hex	1D	5E	r	t	m
	Decimal	29	94	r	t	m

[Range] $0 \leq r \leq 255$
 $0 \leq t \leq 255$
 $m=0,1$

[Description] Executes a macro.
r specifies the number of times to execute the macro.
t specifies the waiting time for executing the macro.
m specifies macro executing mode.
When the LSB of m = 0:
The macro executes r times continuously at the interval specified by t.
When the LSB of m = 1:
After waiting for the period specified by t, the PAPER OUT LED indicators blink and the printer waits for the FEED button to be pressed. After the button is pressed, the printer executes the macro once. The printer repeats the operation r times.

[Notes] The waiting time is $t \times 100$ ms for every macro execution.
If this command is received while a macro is being defined, the macro definition is aborted and the definition is cleared.

TECHNICAL MANUAL

If the macro is not defined or if r is 0, nothing is executed.
 When the macro is executed (m = 1), paper always cannot be fed by using the FEED button.

[Reference] **GS :**

GS a n

[Name] Enable/Disable Automatic Status Back(ASB)

[Format] ASCII GS a n
 Hex 1D 61 n
 Decimal 29 97 n

[Range] $0 \leq n \leq 255$

[Description] Enables or disables ASB and specifies the status items to include, using n as follows:

Bit	Off/ On	Hex	Decimal	Status for ASB
0	Off	00	0	Drawer kick-out connector pin 3 status disabled
	On	01	1	Drawer kick-out connector pin 3 status enabled
1	Off	00	0	On-line/off-line status disabled.
	On	02	2	On-line/off-line status enabled
2	Off	00	0	Error status disabled
	On	04	4	Error status enabled.
3	Off	00	0	Paper roll sensor status disabled
	On	08	8	Paper roll sensor status enabled.
4-7	-	-	-	Undefined

[Notes] If any of the status items in the table above are enabled, the printer transmits the status when this command is executed. The printer automatically transmits the status whenever the enabled status item changes. The disabled status items may change, in this case, because each status transmission represents the current status.

If all status items are disabled, the ASB function is also disabled.

If the ASB is enabled as a default, the printer transmits the status when the printer data reception and transmission is possible at the first time from when the printer is turned on.

The following four status bytes are transmitted without confirming whether the host is ready to receive data. The four status bytes must be consecutive, except for the XOFF code.

Since this command is executed after the data is processed in the receive buffer, there may be a time lag between data reception and status transmission.

When the printer is disabled by **ESC** = (Select peripheral device), the four status bytes are transmitted whenever the status changes.

When using **DLE EOT**, **GS I II I**, or **GS r**, the status transmitted by these

TECHNICAL MANUAL

commands and ASB status must be differentiated, according to the procedure in Appendix G, Transmission Status Identification.

The status to be transmitted are as follows:

First byte (printer information)

Bit	Off/On	Hex	Decimal	Status for ASB
0	Off	00	0	Not used. Fixed to Off
1	Off	00	0	Not used. Fixed to Off
2	Off	00	0	Drawer kick-out connector pin 3 is LOW
	On	04	4	Drawer kick-out connector pin 3 is HIGH
3	Off	00	0	On-line
	On	08	8	Off-line
4	On	10	16	Not used. Fixed to On
5	Off	00	0	Cover is closed
	On	20	32	Cover is open
6	Off	00	0	Paper is not being fed by using the PAPER FEED button
	On	40	64	Paper is being fed by using the PAPER FEED button
7	Off	00	0	Not used. Fixed to Off

Second byte (printer information)

Bit	Off / On	Hex	Decimal	Status for ASB
0	-	-	-	
1	-	-	-	
2	-	-	-	
3	Off	00	0	No auto cutter error
	On	08	8	Auto cutter error occurred
4	Off	00	0	Not used. Fixed to Off
5	Off	00	0	No unrecoverable error
	On	20	32	Unrecoverable error occurred
6	Off	00	0	No automatically recoverable error
	On	40	64	Automatically recoverable error occurred
7	Off	00	0	Not used. Fixed to Off

Bit 3: If these errors occur due to paper jams or the like, it is possible to recover by correcting the cause of the error and executing **DLE ENQ n** ($1 \leq n \leq 2$). If an error due to a circuit failure (e.g. wire break) occurs, it is impossible to recover.

Bit 6: When printing is stopped due to high print head temperature until the print head temperature drops sufficiently or when the paper roll cover is open during printing, bit 6 is On.

Third byte (paper sensor information)

Bit	Off / On	Hex	Decimal	Status for ASB
0,1	Off	00	0	Paper roll near-end sensor: paper adequate
	On	03	3	Paper roll near-end sensor: paper near end
2,3	Off	00	0	Paper roll end sensor: paper present
	On	0C	12	Paper roll end sensor: paper not present
4	Off	00	0	Not used. Fixed to Off

TECHNICAL MANUAL

5,6	-	-	-	Undefined
7	Off	00	0	Not used. Fixed to Off

Fourth byte (paper sensor information)

Bit	Off / On	Hex	Decimal	Status for ASB
0-3	-	-	-	Undefined
4	Off	00	0	Not used. Fixed to Off
5,6	-	-	-	Undefined
7	Off	00	0	Not used. Fixed to Off.

[Default]

[Reference] **DLE EOT, GS**

GS f n

[Name] Select font for HRI characters.

[Format] ASCII GS f n
 Hex 1D 66 n
 Decimal 29 102 n

[Range] $n = 0, 1, 48, 49$

[Description] selects a font for the HRI characters used when printing a bar code.
 n selects the font from the following table.

<i>N</i>	Font
0, 48	Font A (12 x 24)
1	Font B (9 x 24)

HRI means Human Readable Interpretation.

[Notes] HRI characters are printed of the position specified by **GS H**.

[Default] $n = 0$

[Reference] **GS H, GS k**

GS h n

[Name] Select height of bar code.

[Format] ASCII GS h n
 Hex 1D 6B n
 Decimal 29 104 n

TECHNICAL MANUAL

- [Range] $1 \leq n \leq 255$
- [Description] Select the height of the bar code.
 n specifies the number of dots in the vertical direction.
- [Default] $n = 100$
- [Reference] **GS f, GS k**

m GS k m [d1...dk] NUL
i. GS k m n [d1...dn]

- [Name] Print bar code
- [Format] i. ASCII GS k m d1... dk NUL
 Hex 1D 6B m 00
 Decimal 29 107 m 0
 ii. ASCII GS k m n d1... dn
 Hex 1D 6B m n d1... dn
 Decimal 29 107 m n d1... dn
- [Range] i. $0 \leq m \leq 6$ (k and d depends on the code system used)
 ii. $65 \leq m \leq 73$ (n and d depends on the code system used)
- [Description] Selects a bar code system and prints the bar code.
 m selects a bar code system as follows:

M	Bar Code System	Number of Character	Remarks
i.	0	UPC - A	$11 \leq k \leq 12$ $48 \leq d \leq 57$
	1	UPC - E	$7 \leq k \leq 8$ $48 \leq d \leq 57$
	2	EAN13	$12 \leq k \leq 13$ $48 \leq d \leq 57$
	3	EAN8	$7 \leq k \leq 8$ $48 \leq d \leq 57$
	4	CODE39	$1 \leq k$ $48 \leq d \leq 57, 65 \leq d \leq 90,$ $32,36,37,43,45,46,47$
	5	ITF	$1 \leq k$ (even number) $48 \leq d \leq 57$
ii.	6	CODABAR (NW-7)	$1 \leq k$ $48 \leq d \leq 57, 65 \leq d \leq 68,$ $36,43,45,46,47,58$
	65	UPC - A	$11 \leq n \leq 12$ $48 \leq d \leq 57$
	66	UPC - E	$7 \leq n \leq 8$ $48 \leq d \leq 57$
	67	EAN13	$12 \leq n \leq 13$ $48 \leq d \leq 57$
	68	EAN8	$7 \leq n \leq 8$ $48 \leq d \leq 57$
	69	CODE39	$1 \leq n \leq 255$ $48 \leq d \leq 57, 65 \leq d \leq 90,$ $32,36,37,43,45,46,47$
	70	ITF	$1 \leq n \leq 255$ (even number) $48 \leq d \leq 57$
71	CODABAR	$1 \leq n \leq 255$ $48 \leq d \leq 57, 65 \leq d \leq 68,$ $36,43,45,46,47,58$	

TECHNICAL MANUAL

72	CODE93	$1 \leq n \leq 255$	$0 \leq d \leq 127$
73	CODE128	$2 \leq n \leq 255$	$0 \leq d \leq 127$

[Description for i.]

d indicates the character code to be printed and **k** indicates the number of character to be printed.

[Description for ii.]

n indicates the number of bar code data, and the printer processes **n** bytes from the next character data as bar code data.

d indicates the character code to be printed.

[Notes for i.]

This command ends with a NUL code.

When the bar code system used is UPC-A or UPC-E, the printer prints the bar code data after receiving 12 bytes bar code data and processes the following data as normal data.

When the bar code system used is JAN 13, the printer prints the bar code after receiving 13 bytes bar code data and processes the following data as normal data.

When the bar code system used is JAN 8, the printer prints the bar code after receiving 8 bytes bar code data and processes the following data as normal data.

The number of data for ITF bar code must be even numbers.

When an odd number of data is input, the printer ignores the last received data.

[Notes for ii.]

If **n** is outside of the specified range, the printer stops command processing and processes the following data as normal data.

[Notes in standard made]

If **d** is outside of the specified range, the printer only feeds paper and process the following data as normal data.

If the horizontal size exceeds printing area, the printer only feeds the paper.

This command feeds as much paper as is required to print the bar code, regardless of the line spacing specified by **ESC 2** or **ESC 3**.

This command is enabled only when on data exists in the print buffer.

When data exists in the print butter, the printer processes the data following **m** as normal data.

After printing bar code, this command sets the print position to the beginning of the line.

This command is not affected by print modes (emphasized, double-strike, underline, or character size), except for upside-down mode.

[Notes in page made]

This command develops bar coed data in the print buffer, but does not print it.

After processing bar cod data, this command moves the print position to the right side dot of the bar code.

If **d** is out of the specified rang, the printer stops command processing and processes the following data as normal data. In this case, the data butter position does not change.

If bar code width exceeds the printing area, the printer does not print the bar code

TECHNICAL MANUAL

but moves the data buffer position to the left side out of the printing area.
If height of the bar code exceeds the label, exceeding part of the bar code is printed on the next label.

[Reference] **GS H, GS f, GS h, GS w**

GS r n

[Name] Transmit status

[Format] ASCII GS r n
Hex 1D 72 n
Decimal 29 114 n

[Range] n=1, 2, 49, 50

[Description] Transmits the status specified by n as follows:

N	Function
1,49	Transmits paper sensor status
2,50	Transmits drawer kick-out connector status

[Notes] When using a serial interface
When DTR/DSR control is selected, the printer transmits only 1 byte after confirming the host is ready to receive data (DSR signal is SPACE). If the host computer is not ready to receive data (DSR signal is MARK), the printer waits until the host is ready.
When XON/XOFF control is selected, the printer transmits only 1 byte without confirming the condition of the DSR signal.
This command is executed when the data in the receive buffer is developed.
Therefore, there may be a time lag between receiving this command and transmitting the status, depending on the receive buffer status.
When Auto Status Back (ASB) is enabled using **GS a**, the status transmitted by **GS r** and the ASB status must be differentiated using the table in Appendix G.
The status types to be transmitted are shown below:

Paper sensor status (n = 1, 49):

Bit	Off / On	Hex	Decimal	Status for ASB
0,1	Off	00	0	Paper roll near-end sensor: paper adequate
	On	03	3	Paper roll near-end sensor: paper near end
2,3	Off	00	0	Paper roll end sensor: paper adequate
	On	(0C)	(12)	Paper roll end sensor: paper near end
4	Off	00	0	Not used. Fixed to Off
5,6	-	-	-	Undefined
7	Off	00	0	Not used. Fixed to Off

Bits 2 and 3: When the paper end sensor detects a paper end, the printer goes off-line and

TECHNICAL MANUAL

does not execute this command. Therefore, bits 2 and 3 do not transmit the status of paper end.

Drawer kick-out connector status (n = 2, 50):

Bit	Off / On	Hex	Decimal	Function
0	Off	00	0	Drawer kick-out connector pin 3 is LOW
	On	01	1	Drawer kick-out connector pin 3 is HIGH
1-3	-	-	-	Undefined
4	Off	00	0	Not used. Fixed to Off
5,6	-	-	-	Undefined
7	Off	00	0	Not used. Fixed to Off

[Reference] **DLE EOT, GS a**

GS w n

[Name] Set bar code width

[Format] ASCII GS r n
 Hex 1D 77 n
 Decimal 29 119 n

[Range] $2 \leq n \leq 6$

[Description] Set the horizontal size of the bar code.
 N specifies the bar code width as follows:

N	Module width (mm) for Mult-level Bar code	Binary-level Bar Code	
		Thin element width(mm)	Thick element width(mm)
2	0.282	0.282	0.706
3	0.432	0.432	1.129
4	0.564	0.564	1.411
5	0.706	0.706	1.834
6	0.847	0.847	2.258

Multi-level bar codes are as follows:
 UPC-A, UPC-E, JAN13 (EAN13), JAN8 (EAN8), CODE93, CODE128
 Binary-level bar codes are as follows:
 CODE39, ITF, CODABAR

[Default] n = 3

[Reference] **GS k**

TECHNICAL MANUAL

- ADD

ESC i

[Name] Execute paper full cut.

[Format] ASCII ESC i
 Hex 1B 69
 Decimal 27 105

[Description] When this command is received, paper is cut (only when the auto cutter is loaded).

ESC m

[Name] Execute paper partial cut.

[Format] ASCII ESC m
 Hex 1B 6D
 Decimal 27 109

[Description] When this command is received, paper is cut (only when the auto cutter is loaded).